

SiTime MEMS timing benefits

Precision Timing

- 20x better mechanical shock survivability
- 4x better vibration resistance
- 4x better $\Delta F/\Delta T$, airflow and heat resistant

Most Robust in Harsh Conditions

- 50x better acceleration sensitivity
- ± 100 ppb up to 105°C
- No activity dips

Higher Reliability

- Conforms to MIL-PRF-55310
- No quartz reliability issues
- No cover or shielding

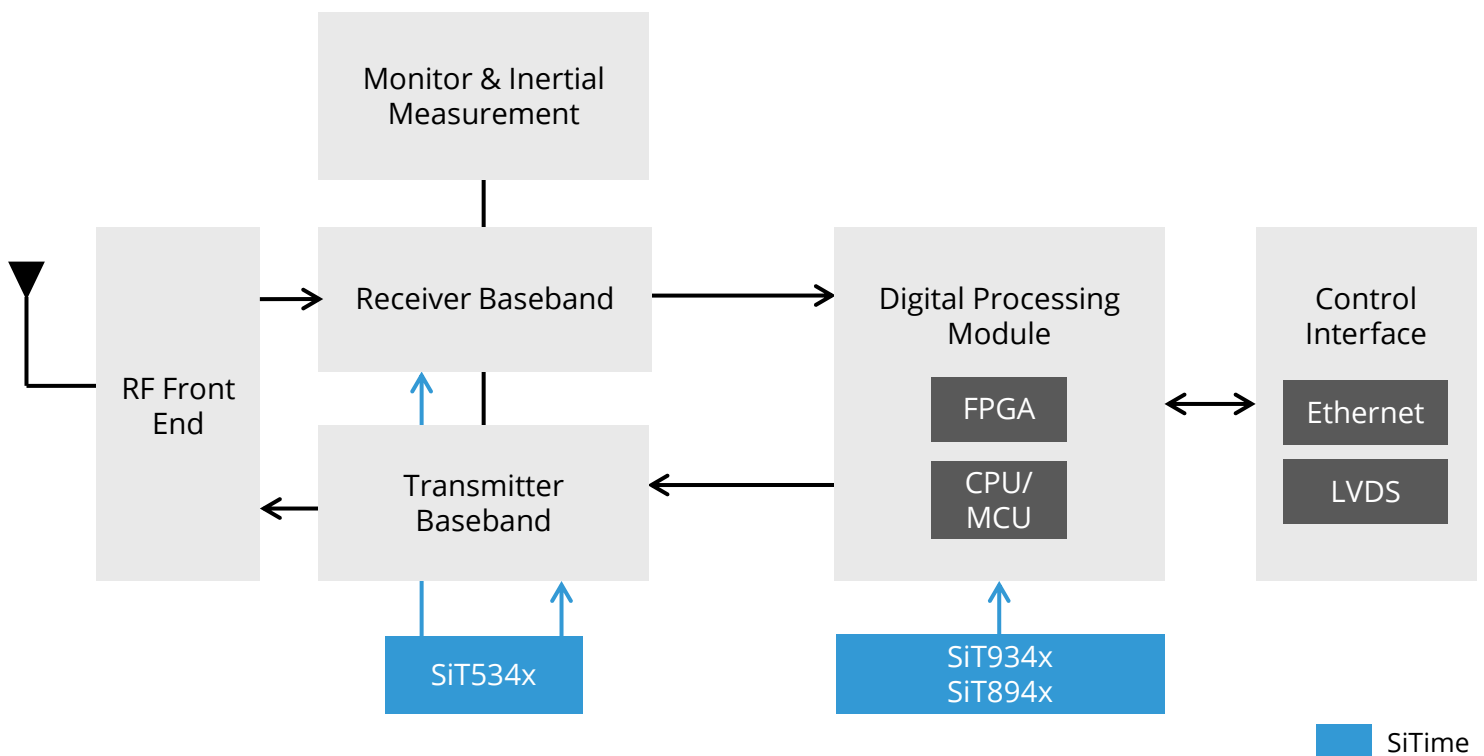

Application	Devices	Type	Function	Key Features
Smart guided munitions	SiT5346 SiT5347 SiT5348 SiT5349	Super-TCXOs	Reference clock for baseband	1 to 220 MHz, 0.004 ppb/g, ± 100 ppb, ± 1 ppb/°C
	SiT9346 SiT9347	Differential XOs	FPGA & processor clocking	1 to 725 MHz, ± 10 ppm, 0.1 ps RMS phase jitter
	SiT8944 SiT8945	Single ended XOs		1 to 137 MHz, ± 20 ppm, -55°C to 125°C

Outperform Quartz

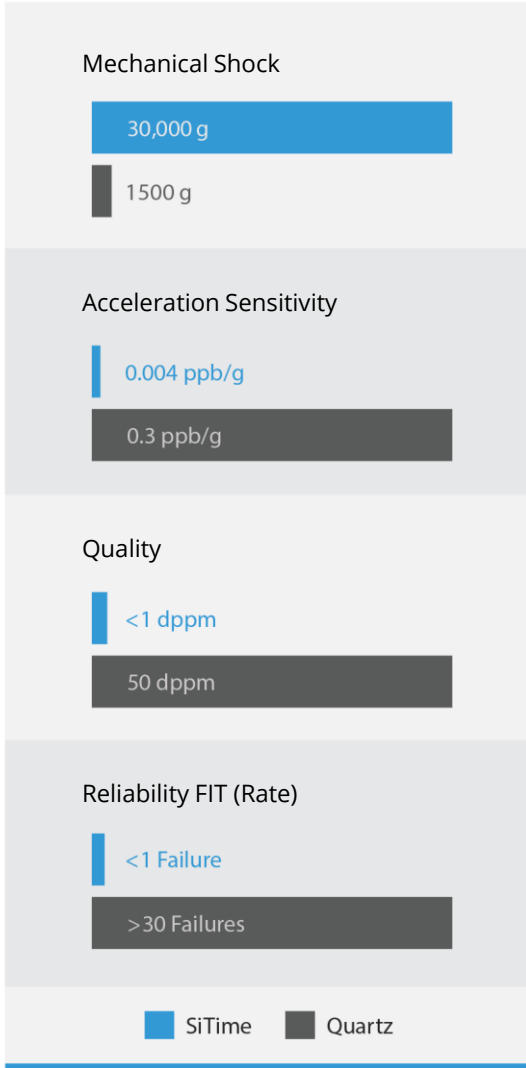

Conforms to MIL Specifications

MIL-PRF-55310	Test	Single-ended XO	Differential XO/ VCXO/DCXO	TCXO
3.6.40.1	Shock	●	●	●
4.8.18.3.1	g-Sensitivity	●	●	●
3.6.34.1	Frequency aging	●	●	●
3.6.17.1	g-sensitivity, constant acceleration	●	●	●
3.6.38.3	Phase noise under vibration	●	●	●
3.6.10.2	Frequency-temperature stability with hysteresis	●	●	●
3.6.45.2	Ambient pressure	●	●	●
3.6.16.5	Allan deviation	n/a	n/a	●
3.6.10.4	Frequency-temperature stability with hysteresis and trim effect	n/a	●	●
3.6.15	Retrace	n/a	n/a	●
3.6.30.7	Modulation frequency response	n/a	●	●
3.6.41.1	Acceleration survivability	●	●	●
3.6.7	Frequency warm up	n/a	n/a	●

Best-In-Class-Aging

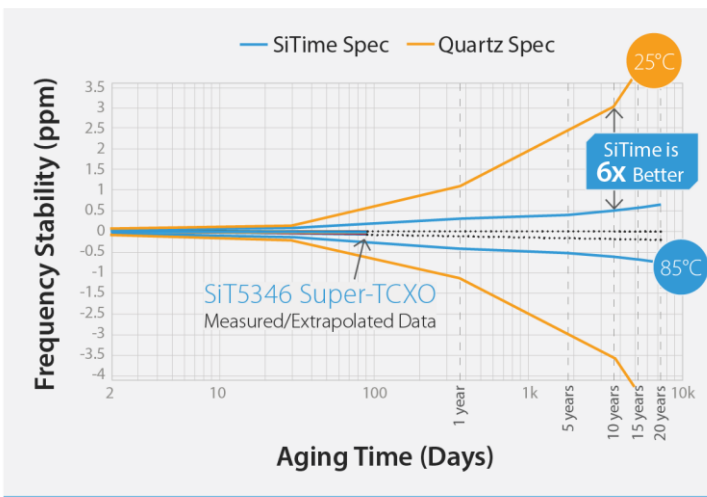

Lower Acceleration (g) Sensitivity

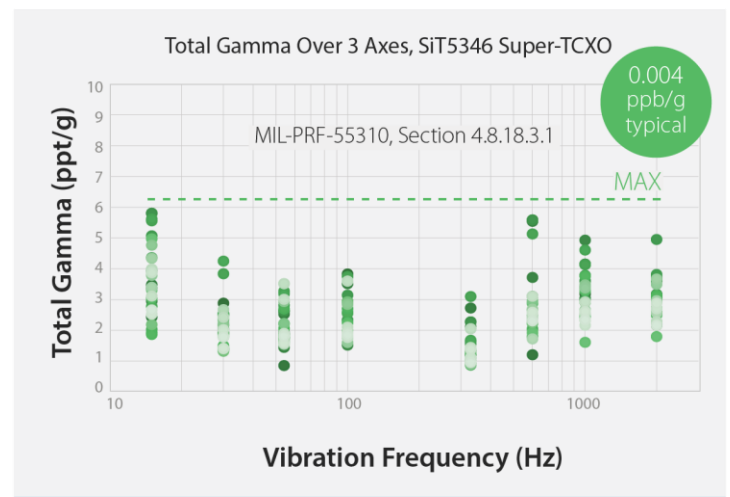

[Learn more](#) about SiTime Aerospace-Defense Timing Solutions



salesupport@sitime.com



www.sitime.com