	<b>Title:</b>	Performance report for SiT3372, 156.25 MHz, LVDS		
	<b>Type:</b>	Performance report	<b>Rev:</b>	1.2
	<b>Orig:</b>		<b>Date:</b>	September 12, 2018

### Performance report for SiT3372 - 156.25 MHz, LVDS

**This performance report contains the following data:**

- Phase noise
- Random phase jitter
- Output waveforms
- Pull range linearity
- Frequency stability over temperature
- Period jitter
- Duty cycle
- Rise/Fall time
- Amplitude
- Current consumption



<b>Title:</b>	Performance report for SiT3372, 156.25 MHz, LVDS		
<b>Type:</b>	Performance report	<b>Rev:</b>	1.2
<b>Orig:</b>		<b>Date:</b>	September 12, 2018

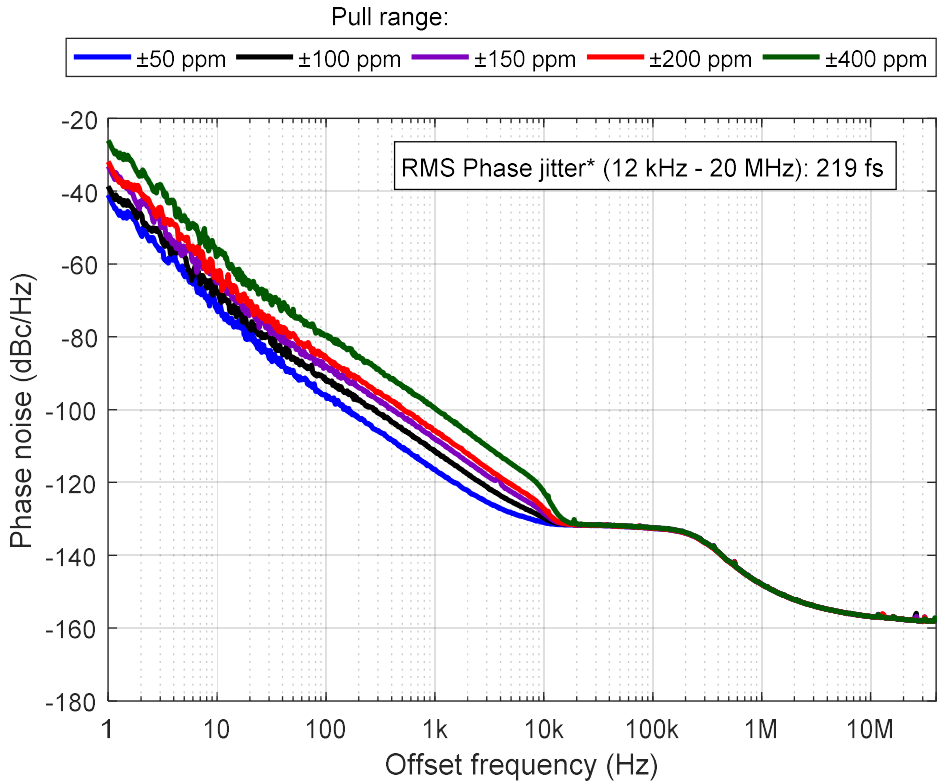

Figure 1: Phase noise, 3.3 V

*\*Integrated phase jitter value applies for ±50 ppm to ±400 ppm pull ranges*

Table 1: Phase noise

Phase noise dBc/Hz					
Frequency offset (Hz)	Pull range (ppm)				
	±50	±100	±150	±200	±400
1	-41.1	-38.7	-33.1	-31.9	-26.1
10	-72.8	-67.7	-65.1	-63.2	-57.7
100	-95.9	-91.7	-88.4	-85.6	-79.6
1 K	-116.4	-111.2	-108.1	-105.8	-99.6
10 K	-131.0	-129.7	-128.5	-127.2	-122.6
100 K	-132.6	-132.4	-132.4	-132.6	-132.4
1 M	-147.9	-148.0	-148.0	-148.0	-148.0
10 M	-156.8	-156.8	-156.8	-156.8	-156.8
40 M	-158.1	-158.1	-158.1	-158.1	-158.1

	<b>Title:</b>	Performance report for SiT3372, 156.25 MHz, LVDS		
	<b>Type:</b>	Performance report	<b>Rev:</b>	1.2
	<b>Orig:</b>		<b>Date:</b>	September 12, 2018

Table 2: Integrated Phase jitter

Parameter	Units	Pull range (ppm)
		±50 to ±400
Integrated Phase jitter (1.875 MHz - 20 MHz)	fs, rms	94
Integrated Phase jitter (12 kHz - 20 MHz)	fs, rms	219

**The information contained in this document is confidential and proprietary to SiTime Corporation. Unauthorized reproduction or distribution is prohibited.**

	<b>Title:</b>	Performance report for SiT3372, 156.25 MHz, LVDS		
	<b>Type:</b>	Performance report	<b>Rev:</b>	1.2
	<b>Orig:</b>		<b>Date:</b>	September 12, 2018



Figure 2: Output waveform, 2.5 V



Figure 3: Output waveform, 3.3 V

The information contained in this document is confidential and proprietary to SiTime Corporation. Unauthorized reproduction or distribution is prohibited.



<b>Title:</b>	Performance report for SiT3372, 156.25 MHz, LVDS		
<b>Type:</b>	Performance report	<b>Rev:</b>	1.2
<b>Orig:</b>		<b>Date:</b>	September 12, 2018

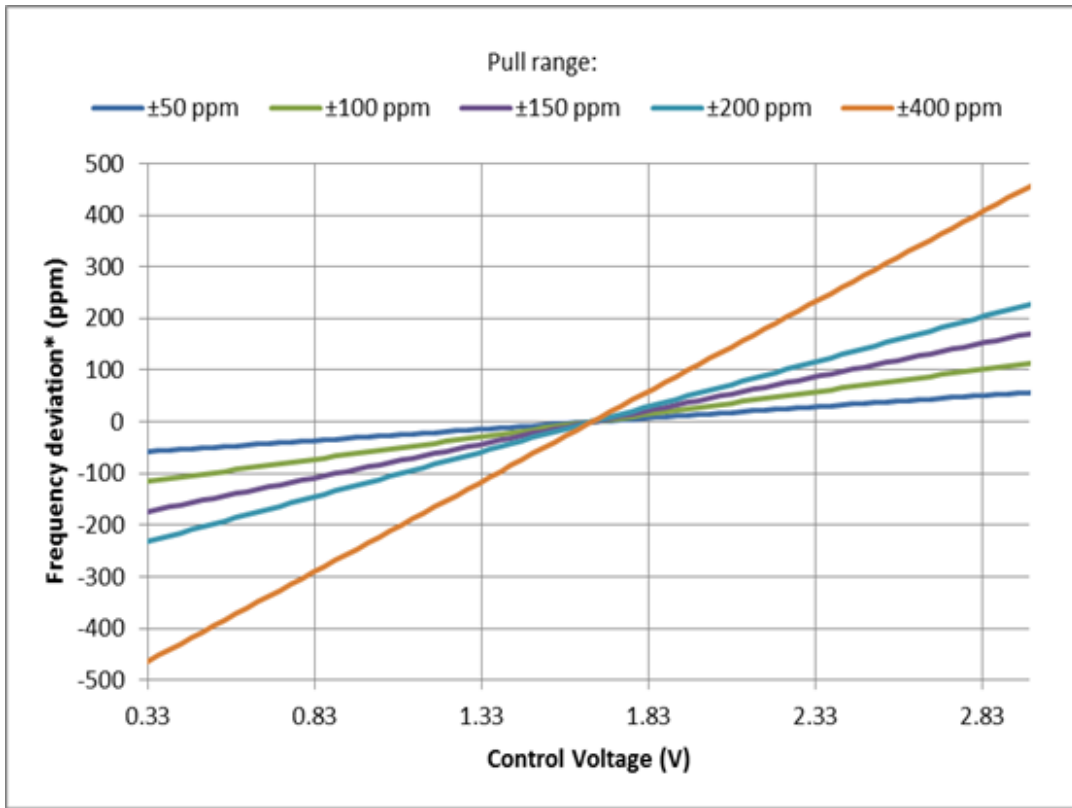

Figure 4: Frequency pull characteristic

<b>SiTime</b>	<b>Title:</b>	Performance report for SiT3372, 156.25 MHz, LVDS		
	<b>Type:</b>	Performance report	<b>Rev:</b>	1.2
	<b>Orig:</b>		<b>Date:</b>	September 12, 2018

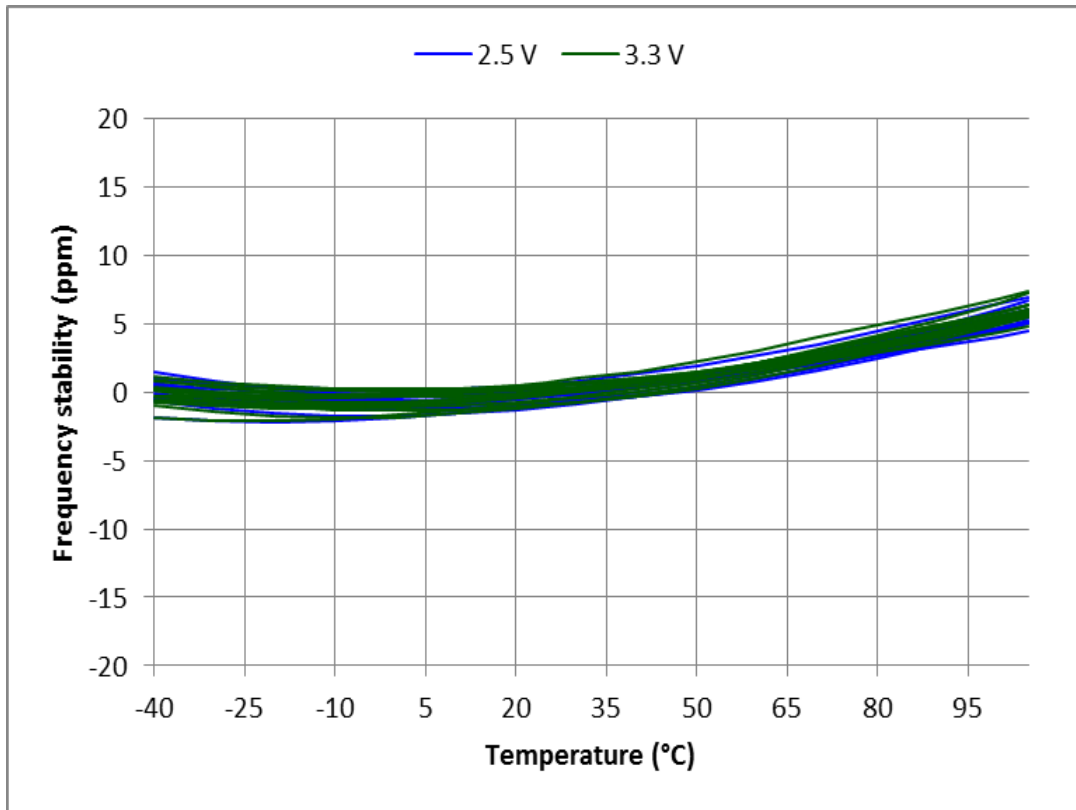

Figure 5: Frequency stability\* over temperature, 2.5 V – 3.3 V, 30 devices

\*SiT3372 frequency stability is independent of output frequency.

The information contained in this document is confidential and proprietary to SiTime Corporation. Unauthorized reproduction or distribution is prohibited.



	<b>Title:</b>	Performance report for SiT3372, 156.25 MHz, LVDS		
	<b>Type:</b>	Performance report	<b>Rev:</b>	1.2
	<b>Orig:</b>		<b>Date:</b>	September 12, 2018

Table 3: Summary performance data

Parameter	Units	Voltage	
		2.5 V	3.3 V
Period jitter	ps, rms	0.71	0.74
Period jitter (sample size 10,000 cycles)	ps, pk-pk	5.56	5.53
Duty cycle	%	49.9	49.7
Rise time (20% - 80%)	ps	400	390
Fall time (80% - 20%)	ps	397	396
Differential voltage swing	V	0.83	0.82
Current consumption (no load, output enabled)	mA	75.4	75.5
Current consumption (no load, output disabled)	mA	57.7	57.8

	<b>Title:</b>	Performance report for SiT3372, 156.25 MHz, LVDS		
	<b>Type:</b>	Performance report	<b>Rev:</b>	1.2
	<b>Orig:</b>		<b>Date:</b>	September 12, 2018

## Test description

### Conditions:

- Frequency: 156.25 MHz
- VDD: 2.5 V, 3.3 V
- Pull range:  $\pm 50$  ppm,  $\pm 100$  ppm,  $\pm 150$  ppm,  $\pm 200$  ppm,  $\pm 400$  ppm
- Temperature: 25 °C

### Equipment:

Model	Measurement / Purpose
Keysight DSA90604A (6 GHz, 20 Gsps)	Period jitter, output amplitude, rise/fall time, duty cycle
Keysight 5052B Signal Source Analyzer	Phase noise, integrated phase jitter
Keysight 34980A	Power supply current
Keysight E3631A	Power supply
Keysight 53230A	Frequency



	<b>Title:</b>	Performance report for SiT3372, 156.25 MHz, LVDS		
	<b>Type:</b>	Performance report	<b>Rev:</b>	1.2
	<b>Orig:</b>		<b>Date:</b>	September 12, 2018

## Setup

### Waveform

For waveform parameters measurement (rise/fall time, differential swing, duty cycle), both DUT outputs are terminated with 100  $\Omega$  differential. Output signals are measured using Keysight 1134B active probe with Keysight N5425B probe head. All measurements are applied to the differential waveform. Figure 6 shows test setup diagram for waveform parameters measurement.

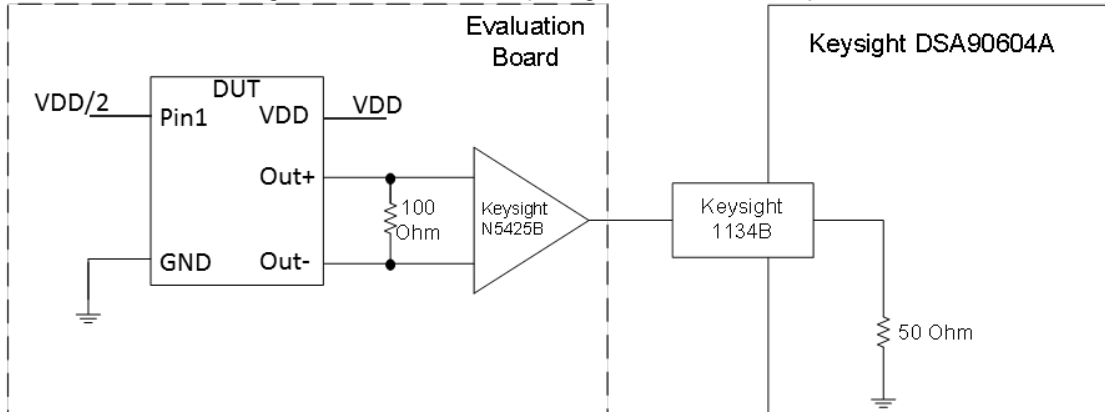

Figure 6. Test setup for measuring waveform parameters (rise/fall time, differential swing, duty cycle)

### Period Jitter

For period jitter measurement outputs are connected through AC-coupling capacitors to the oscilloscope channels. Signals are subtracted inside the oscilloscope. All measurements applied to differential waveform. Figure 7 shows test setup diagram for period jitter measurement.

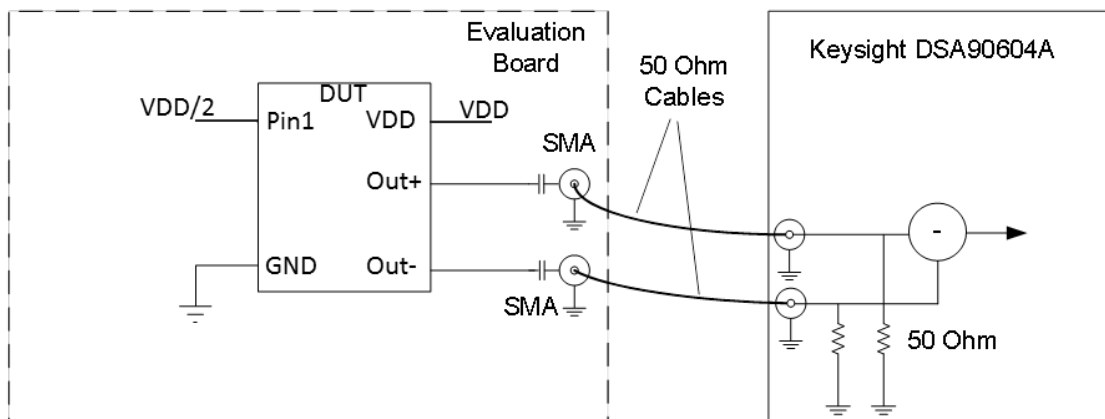



Figure 7. Test setup for measuring period jitter

	<b>Title:</b>	Performance report for SiT3372, 156.25 MHz, LVDS		
	<b>Type:</b>	Performance report	<b>Rev:</b>	1.2
	<b>Orig:</b>		<b>Date:</b>	September 12, 2018

**Phase noise**

For phase noise measurements, differential signal is converted to single-ended using impedance matching transformer. Transformer's output is connected to measurement instrument. Figure 8 shows test setup diagram for phase noise measurement.

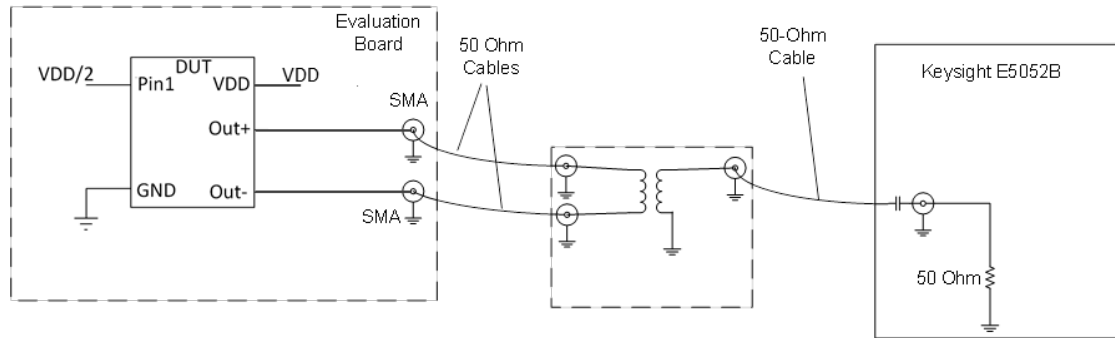

Figure 8. Test setup for measuring phase noise.

**Current consumption**

For Current consumption measurement device output is floating. For frequency measurement differential-to-single-ended converter is used.