	<b>Title:</b>	Performance report for SiT3373, 245.76 MHz, HCSL		
	<b>Type:</b>	Performance report	<b>Rev:</b>	1.2
	<b>Orig:</b>		<b>Date:</b>	September 07, 2018

## Performance report for SiT3373 - 245.76 MHz, HCSL

### This performance report contains the following data:

- Phase noise
- Random phase jitter
- Output waveforms
- Pull range linearity
- Frequency stability over temperature
- Period jitter
- Duty cycle
- Rise/Fall time
- Amplitude
- Current consumption



<b>Title:</b>	Performance report for SiT3373, 245.76 MHz, HCSL		
<b>Type:</b>	Performance report	<b>Rev:</b>	1.2
<b>Orig:</b>		<b>Date:</b>	September 07, 2018

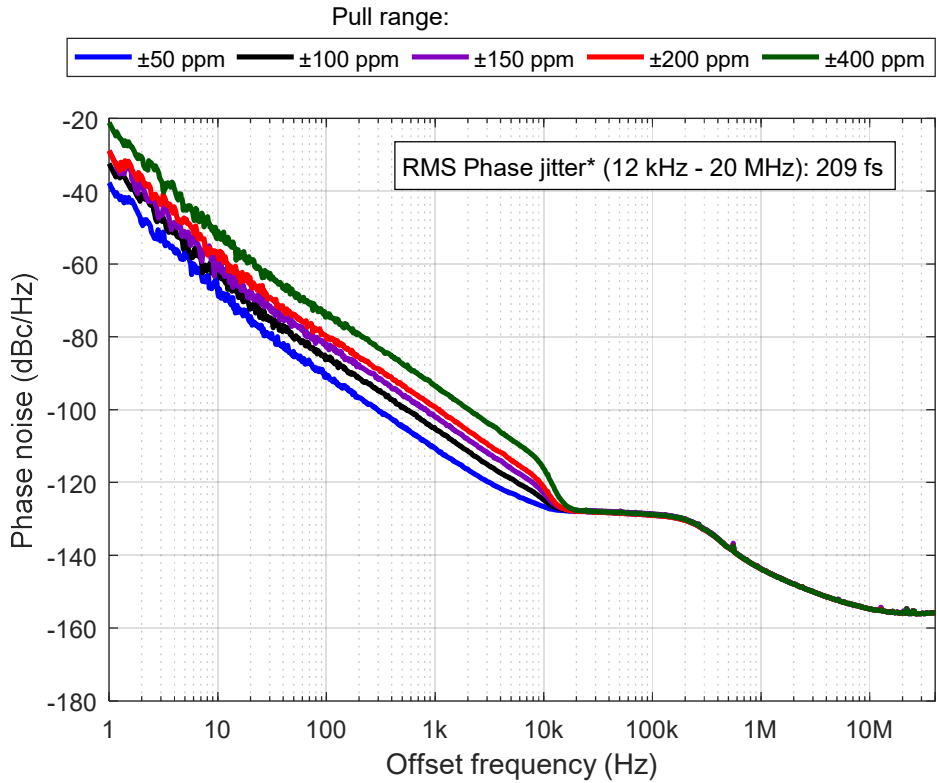

Figure 1: Phase noise, 3.3 V

*\*Integrated phase jitter value applies for ±50 ppm to ±400 ppm pull ranges*

Table 1: Phase noise

Phase noise dBc/Hz					
Frequency offset (Hz)	Pull range (ppm)				
	±50	±100	±150	±200	±400
1	-37.7	-32.4	-28.9	-28.9	-21.1
10	-68.0	-61.9	-58.8	-57.2	-51.0
100	-90.7	-85.5	-82.9	-80.2	-73.9
1 K	-110.6	-105.2	-102.0	-99.3	-93.5
10 K	-126.6	-124.7	-123.0	-121.2	-116.2
100 K	-129.0	-128.7	-128.7	-129.0	-128.8
1 M	-143.7	-143.7	-143.7	-143.8	-143.8
10 M	-154.7	-154.7	-154.8	-154.7	-154.7
40 M	-155.8	-155.8	-155.8	-155.8	-155.8

**The information contained in this document is confidential and proprietary to SiTime Corporation. Unauthorized reproduction or distribution is prohibited.**

	<b>Title:</b>	Performance report for SiT3373, 245.76 MHz, HCSL		
	<b>Type:</b>	Performance report	<b>Rev:</b>	1.2
	<b>Orig:</b>		<b>Date:</b>	September 07, 2018

Table 2: Integrated Phase jitter

Parameter	Units	Pull range (ppm)
		±50 to ±400
Integrated Phase jitter (1.875 MHz - 20 MHz)	fs, rms	81
Integrated Phase jitter (12 kHz - 20 MHz)	fs, rms	209

	<b>Title:</b>	Performance report for SiT3373, 245.76 MHz, HCSL		
	<b>Type:</b>	Performance report	<b>Rev:</b>	1.2
	<b>Orig:</b>		<b>Date:</b>	September 07, 2018



Figure 2: Output waveform, 2.5 V



Figure 3: Output waveform, 3.3 V

The information contained in this document is confidential and proprietary to SiTime Corporation. Unauthorized reproduction or distribution is prohibited.



<b>Title:</b>	Performance report for SiT3373, 245.76 MHz, HCSL		
<b>Type:</b>	Performance report	<b>Rev:</b>	1.2
<b>Orig:</b>		<b>Date:</b>	September 07, 2018

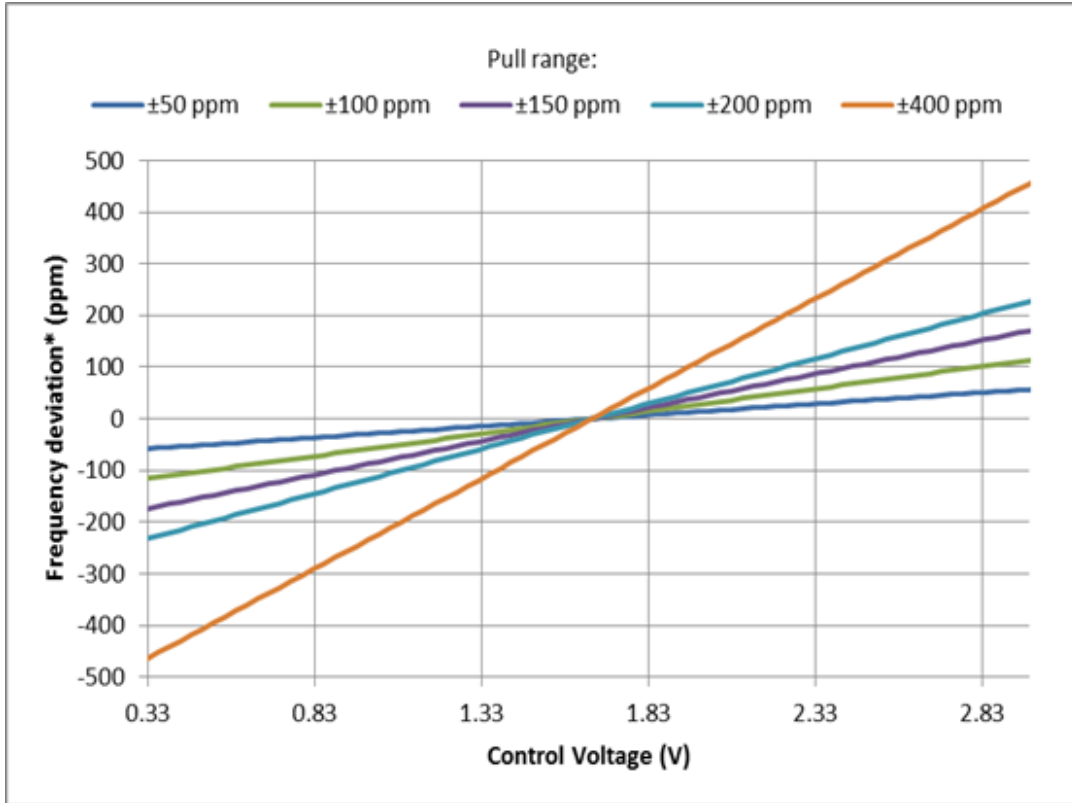

Figure 4: Frequency pull characteristic

<b>SiTime</b>	<b>Title:</b>	Performance report for SiT3373, 245.76 MHz, HCSL		
	<b>Type:</b>	Performance report	<b>Rev:</b>	1.2
	<b>Orig:</b>		<b>Date:</b>	September 07, 2018

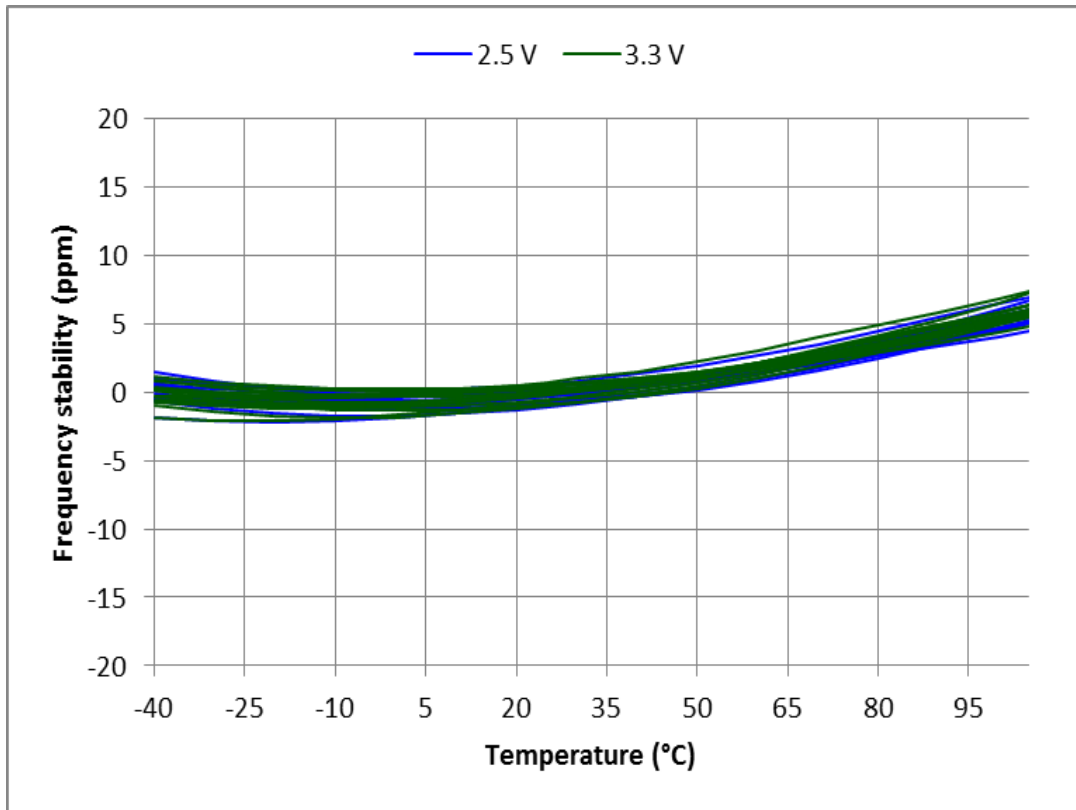

Figure 5: Frequency stability\* over temperature, 2.5 V – 3.3 V, 30 devices

\*SiT3373 frequency stability is independent of output frequency.

The information contained in this document is confidential and proprietary to SiTime Corporation. Unauthorized reproduction or distribution is prohibited.



	<b>Title:</b>	Performance report for SiT3373, 245.76 MHz, HCSL		
	<b>Type:</b>	Performance report	<b>Rev:</b>	1.2
	<b>Orig:</b>		<b>Date:</b>	September 07, 2018

Table 3: Summary performance data

Parameter	Units	Voltage	
		2.5 V	3.3 V
Period jitter	ps, rms	1.01	1.02
Period jitter (sample size 10,000 cycles)	ps, pk-pk	8.08	7.92
Duty cycle	%	50.0	50.0
Rise time (20% - 80%)	ps	389	385
Fall time (80% - 20%)	ps	389	385
Differential voltage swing	V	1.59	1.65
Current consumption (no load, output enabled)	mA	84.6	85.4
Current consumption (no load, output disabled)	mA	56.1	56.2

	<b>Title:</b>	Performance report for SiT3373, 245.76 MHz, HCSL		
	<b>Type:</b>	Performance report	<b>Rev:</b>	1.2
	<b>Orig:</b>		<b>Date:</b>	September 07, 2018

## Test description

### Conditions:

- Frequency: 245.76 MHz
- VDD: 2.5 V, 3.3 V
- Pull range:  $\pm 50$  ppm,  $\pm 100$  ppm,  $\pm 150$  ppm,  $\pm 200$  ppm,  $\pm 400$  ppm
- Temperature: 25 °C

### Equipment:

Model	Measurement / Purpose
Keysight DSA90604A (6 GHz, 20 Gsps)	Period jitter, output amplitude, rise/fall time, duty cycle
Keysight 5052B Signal Source Analyzer	Phase noise, integrated phase jitter
Keysight 34980A	Power supply current
Keysight E3631A	Power supply
Keysight 53230A	Frequency



	<b>Title:</b>	Performance report for SiT3373, 245.76 MHz, HCSL		
	<b>Type:</b>	Performance report	<b>Rev:</b>	1.2
	<b>Orig:</b>		<b>Date:</b>	September 07, 2018

## Setup

### Waveform

For waveform parameters measurement (rise/fall time, differential swing, duty cycle), both DUT outputs are terminated with 30  $\Omega$  series and 50  $\Omega$  to GND. Output signals are measured using Keysight 1134B active probe with Keysight N5425B probe head. All measurements are applied to the differential waveform. Figure 6 shows test setup diagram for waveform parameters measurement.

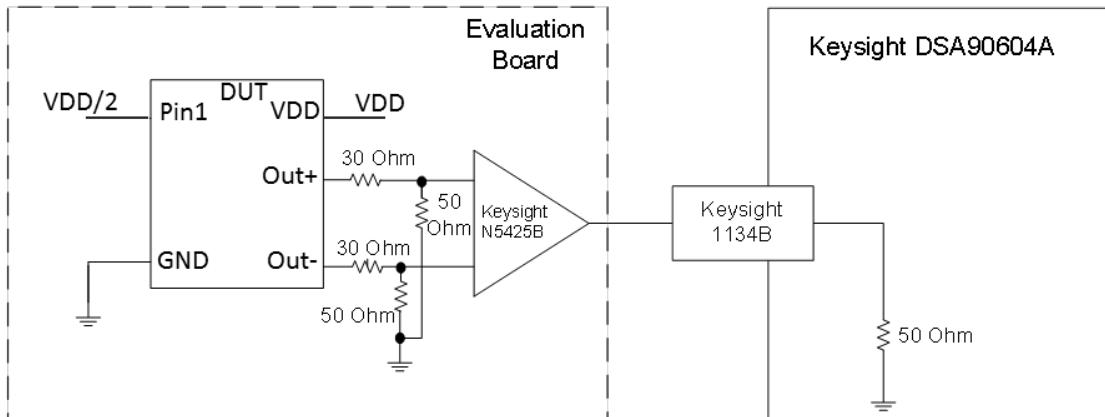

Figure 6. Test setup for measuring waveform parameters (rise/fall time, differential swing, duty cycle)

### Period Jitter

For period jitter measurement output is terminated with 30  $\Omega$  series and 50  $\Omega$  to GND at the input of hi-speed comparator (ADCMP581). AC coupled comparator's output is connected to oscilloscope channel. Figure 7 shows test setup diagram for period jitter measurement.

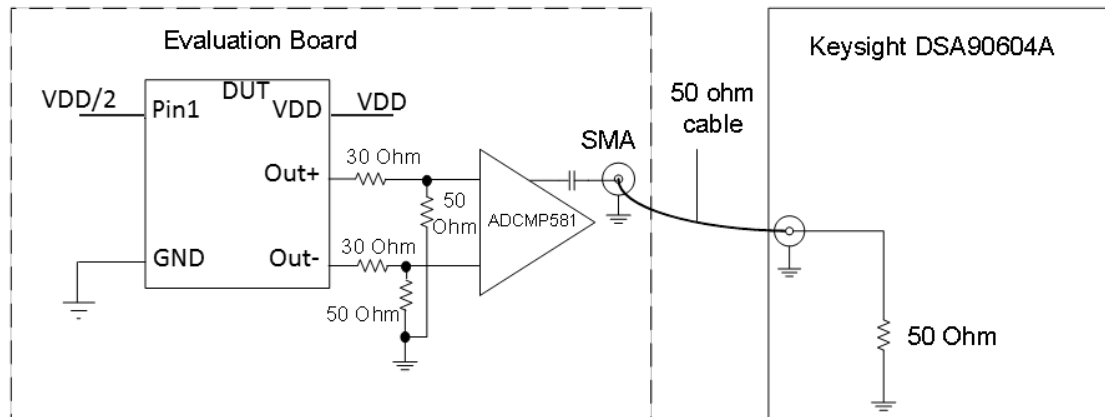



Figure 7. Test setup for measuring period jitter

	<b>Title:</b>	Performance report for SiT3373, 245.76 MHz, HCSL		
	<b>Type:</b>	Performance report	<b>Rev:</b>	1.2
	<b>Orig:</b>		<b>Date:</b>	September 07, 2018

**Phase noise**

For phase noise measurements, differential signal is converted to single-ended using impedance matching transformer. Transformer's output is connected to measurement instrument. Output is also terminated with 30 Ω series at the source side. Figure 8 shows test setup diagram for phase noise measurement.

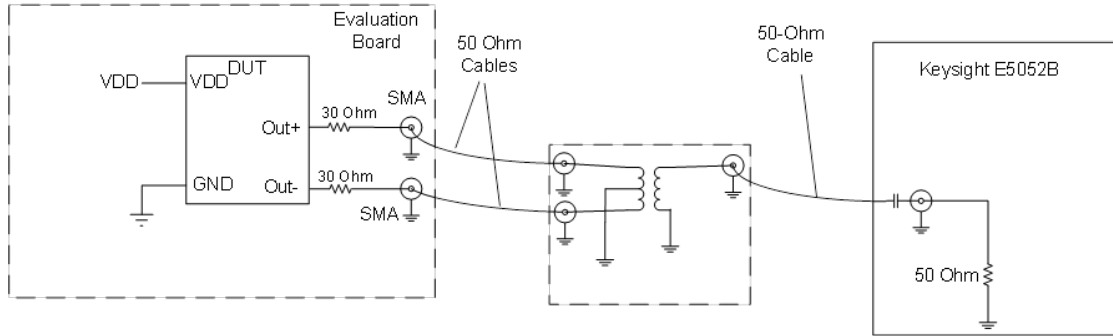

Figure 8. Test setup for measuring phase noise.

**Current consumption**

For Current consumption measurement device output is floating. For frequency measurement differential-to-single-ended converter is used.