	Title:	Performance report for SiT3373, 698.812335 MHz, LVDS		
	Type:	Performance report	Rev:	1.2
	Orig:		Date:	September 07, 2018

Performance report for SiT3373 - 698.812335 MHz, LVDS

This performance report contains the following data:

- Phase noise
- Random phase jitter
- Output waveforms
- Pull range linearity
- Frequency stability over temperature
- Period jitter
- Duty cycle
- Rise/Fall time
- Amplitude
- Current consumption



Title:	Performance report for SiT3373, 698.812335 MHz, LVDS		
Type:	Performance report	Rev:	1.2
Orig:		Date:	September 07, 2018

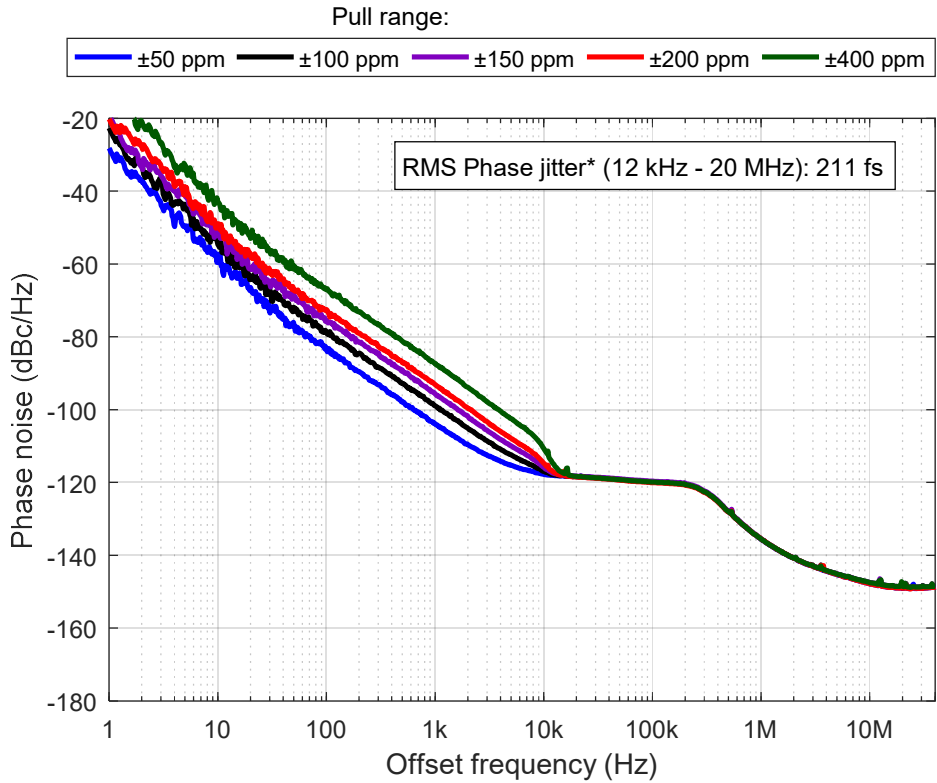

Figure 1: Phase noise, 3.3 V

**Integrated phase jitter value applies for ±50 ppm to ±400 ppm pull ranges*

Table 1: Phase noise

Phase noise dBc/Hz					
Frequency offset (Hz)	Pull range (ppm)				
	±50	±100	±150	±200	±400
1	-28.2	-22.7	-19.0	-20.2	-12.8
10	-58.7	-54.6	-51.3	-49.0	-42.9
100	-83.4	-78.5	-75.5	-72.5	-67.0
1 K	-104.0	-98.9	-95.7	-93.1	-87.3
10 K	-117.7	-117.0	-115.8	-114.7	-110.7
100 K	-119.9	-119.9	-119.6	-120.1	-119.9
1 M	-135.6	-135.5	-135.5	-135.5	-135.5
10 M	-147.8	-147.5	-147.5	-147.8	-147.5
40 M	-148.8	-148.6	-148.5	-148.8	-148.5



	Title:	Performance report for SiT3373, 698.812335 MHz, LVDS		
	Type:	Performance report	Rev:	1.2
	Orig:		Date:	September 07, 2018

Table 2: Integrated Phase jitter

Parameter	Units	Pull range (ppm)
		±50 to ±400
Integrated Phase jitter (1.875 MHz - 20 MHz)	fs, rms	65
Integrated Phase jitter (12 kHz - 20 MHz)	fs, rms	211

The information contained in this document is confidential and proprietary to SiTime Corporation. Unauthorized reproduction or distribution is prohibited.

	Title:	Performance report for SiT3373, 698.812335 MHz, LVDS		
	Type:	Performance report	Rev:	1.2
	Orig:		Date:	September 07, 2018

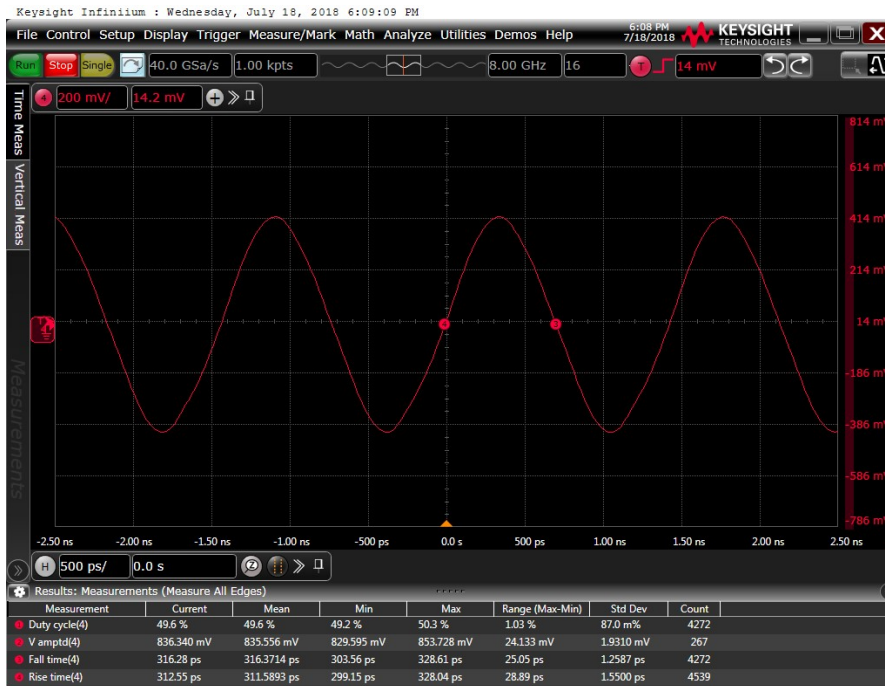

Figure 2: Output waveform, 2.5 V



Figure 3: Output waveform, 3.3 V

The information contained in this document is confidential and proprietary to SiTime Corporation. Unauthorized reproduction or distribution is prohibited.



Title:	Performance report for SiT3373, 698.812335 MHz, LVDS		
Type:	Performance report	Rev:	1.2
Orig:		Date:	September 07, 2018

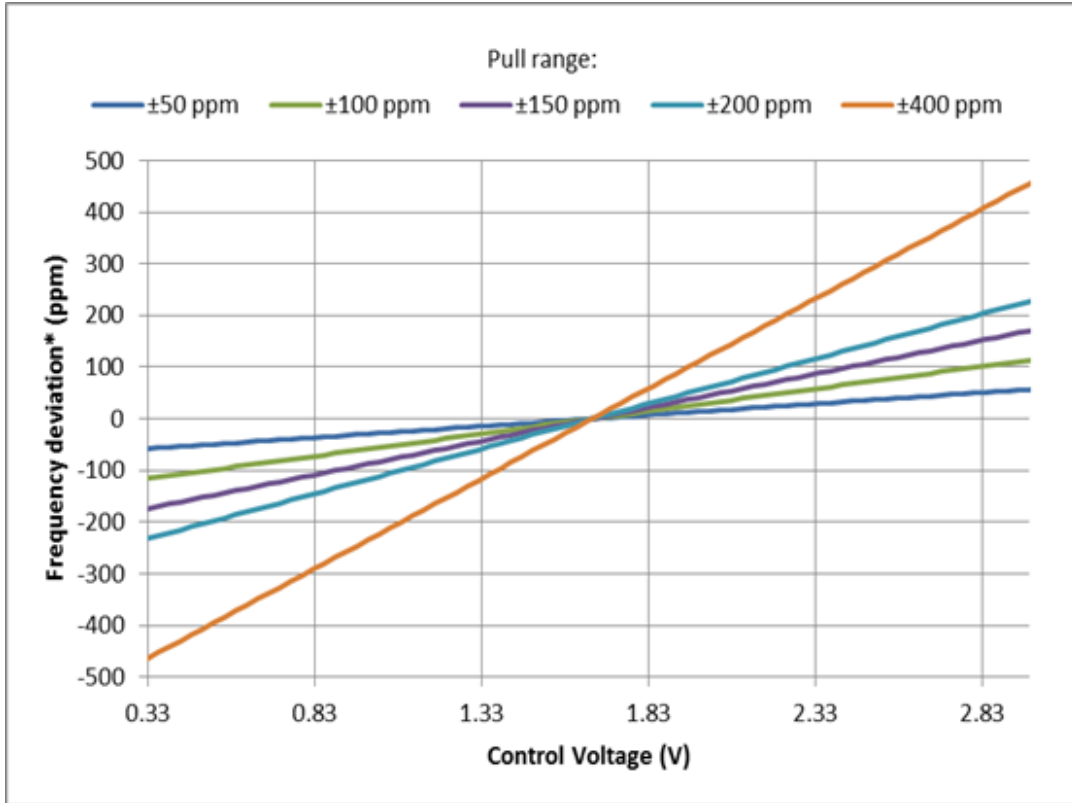

Figure 4: Frequency pull characteristic

SiTime	Title:	Performance report for SiT3373, 698.812335 MHz, LVDS		
	Type:	Performance report	Rev:	1.2
	Orig:		Date:	September 07, 2018

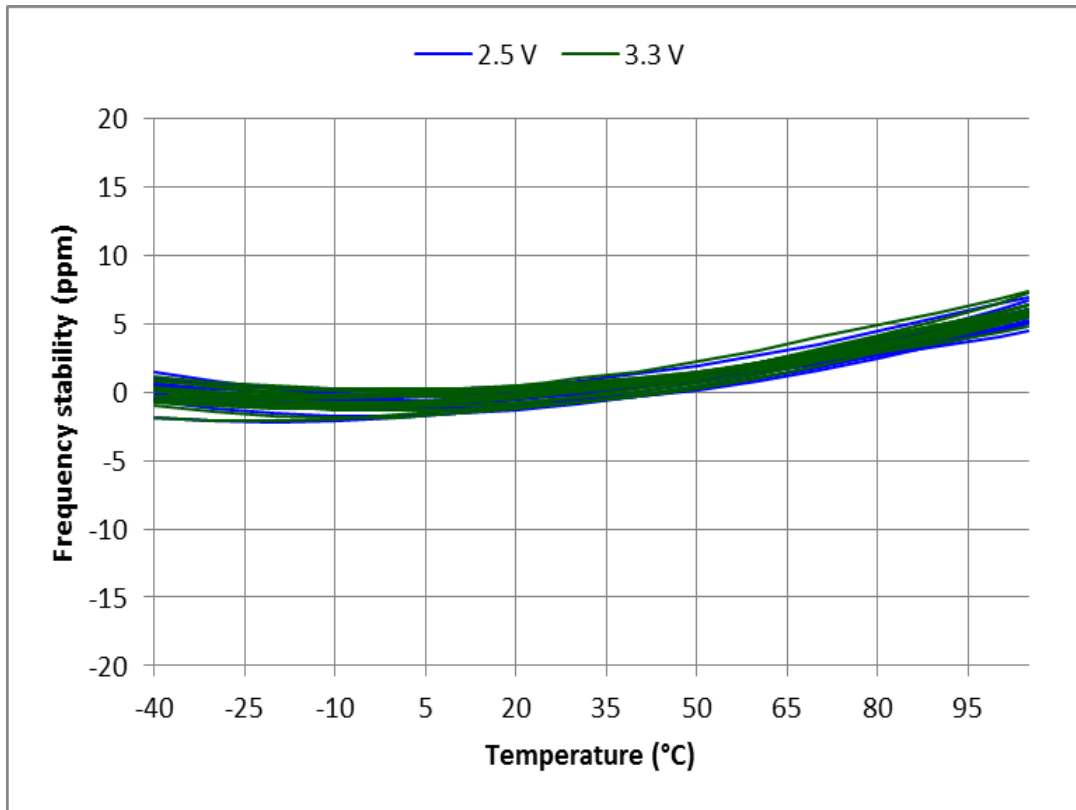

Figure 5: Frequency stability* over temperature, 2.5 V – 3.3 V, 30 devices

*SiT3373 frequency stability is independent of output frequency.

The information contained in this document is confidential and proprietary to SiTime Corporation. Unauthorized reproduction or distribution is prohibited.



	Title:	Performance report for SiT3373, 698.812335 MHz, LVDS		
	Type:	Performance report	Rev:	1.2
	Orig:		Date:	September 07, 2018

Table 3: Summary performance data

Parameter	Units	Voltage	
		2.5 V	3.3 V
Period jitter	ps, rms	0.80	0.79
Period jitter (sample size 10,000 cycles)	ps, pk-pk	6.13	6.06
Duty cycle	%	49.6	49.6
Rise time (20% - 80%)	ps	312	308
Fall time (80% - 20%)	ps	316	313
Differential voltage swing	V	0.84	0.83
Current consumption (no load, output enabled)	mA	76.3	76.4
Current consumption (no load, output disabled)	mA	55.1	55.2

	Title:	Performance report for SiT3373, 698.812335 MHz, LVDS		
	Type:	Performance report	Rev:	1.2
	Orig:		Date:	September 07, 2018

Test description

Conditions:

- Frequency: 698.812335 MHz
- VDD: 2.5 V, 3.3 V
- Pull range: ± 50 ppm, ± 100 ppm, ± 150 ppm, ± 200 ppm, ± 400 ppm
- Temperature: 25 °C

Equipment:

Model	Measurement / Purpose
Keysight DSA90604A (6 GHz, 20 Gbps)	Period jitter, output amplitude, rise/fall time, duty cycle
Keysight 5052B Signal Source Analyzer	Phase noise, integrated phase jitter
Keysight 34980A	Power supply current
Keysight E3631A	Power supply
Keysight 53230A	Frequency

	Title:	Performance report for SiT3373, 698.812335 MHz, LVDS		
	Type:	Performance report	Rev:	1.2
	Orig:		Date:	September 07, 2018

Setup

Waveform

For waveform parameters measurement (rise/fall time, differential swing, duty cycle), both DUT outputs are terminated with 100 Ω differential. Output signals are measured using Keysight 1134B active probe with Keysight N5425B probe head. All measurements are applied to the differential waveform. Figure 6 shows test setup diagram for waveform parameters measurement.

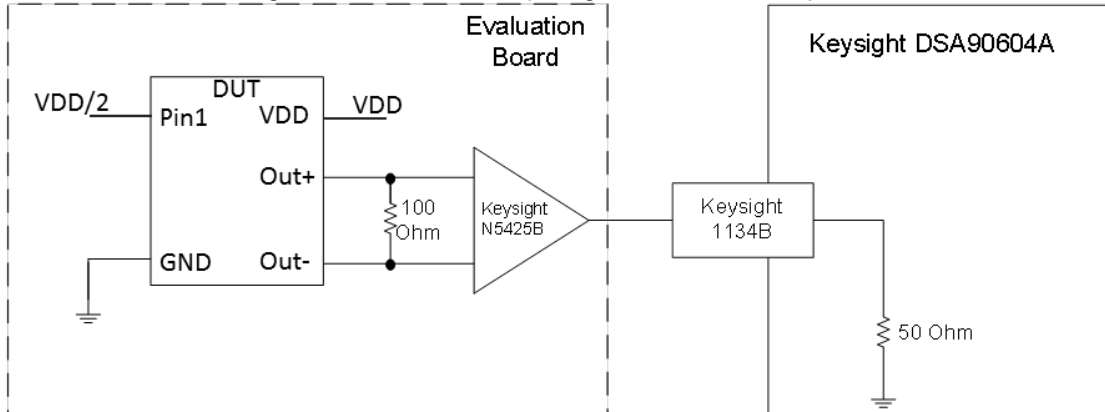

Figure 6. Test setup for measuring waveform parameters (rise/fall time, differential swing, duty cycle)

Period Jitter

For period jitter measurement outputs are connected through AC-coupling capacitors to the oscilloscope channels. Signals are subtracted inside the oscilloscope. All measurements applied to differential waveform. Figure 7 shows test setup diagram for period jitter measurement.

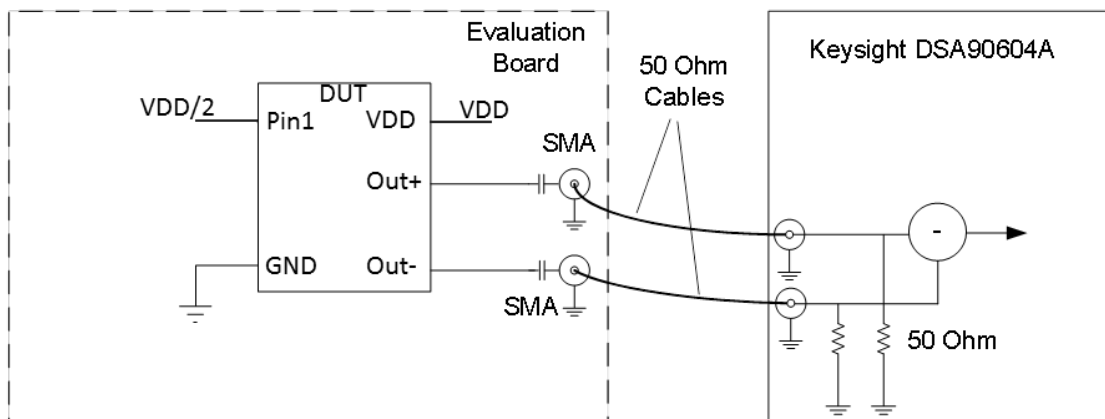



Figure 7. Test setup for measuring period jitter

	Title:	Performance report for SiT3373, 698.812335 MHz, LVDS		
	Type:	Performance report	Rev:	1.2
	Orig:		Date:	September 07, 2018

Phase noise

For phase noise measurements, differential signal is converted to single-ended using impedance matching transformer. Transformer's output is connected to measurement instrument. Figure 8 shows test setup diagram for phase noise measurement.

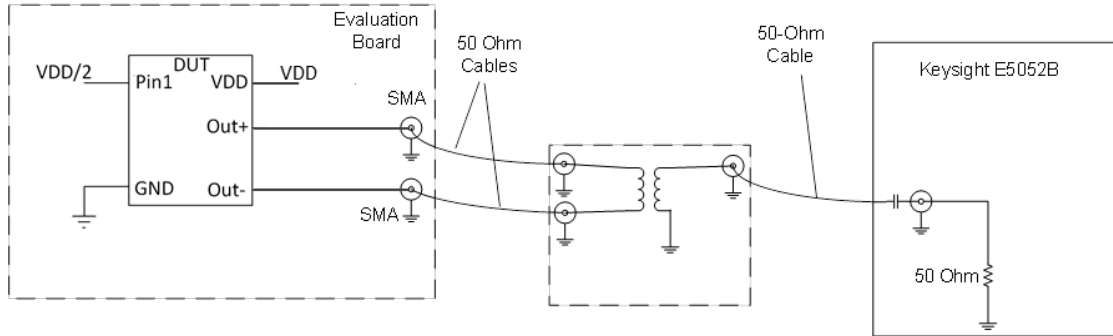

Figure 8. Test setup for measuring phase noise.

Current consumption

For Current consumption measurement device output is floating. For frequency measurement differential-to-single-ended converter is used.