	Title:	Performance report for SiT3373, 625 MHz, LVPECL		
	Type:	Performance report	Rev:	1.2
	Orig:		Date:	September 07, 2018

Performance report for SiT3373 - 625 MHz, LVPECL

This performance report contains the following data:

- Phase noise
- Random phase jitter
- Output waveforms
- Pull range linearity
- Frequency stability over temperature
- Period jitter
- Duty cycle
- Rise/Fall time
- Amplitude
- Current consumption



Title:	Performance report for SiT3373, 625 MHz, LVPECL		
Type:	Performance report	Rev:	1.2
Orig:		Date:	September 07, 2018

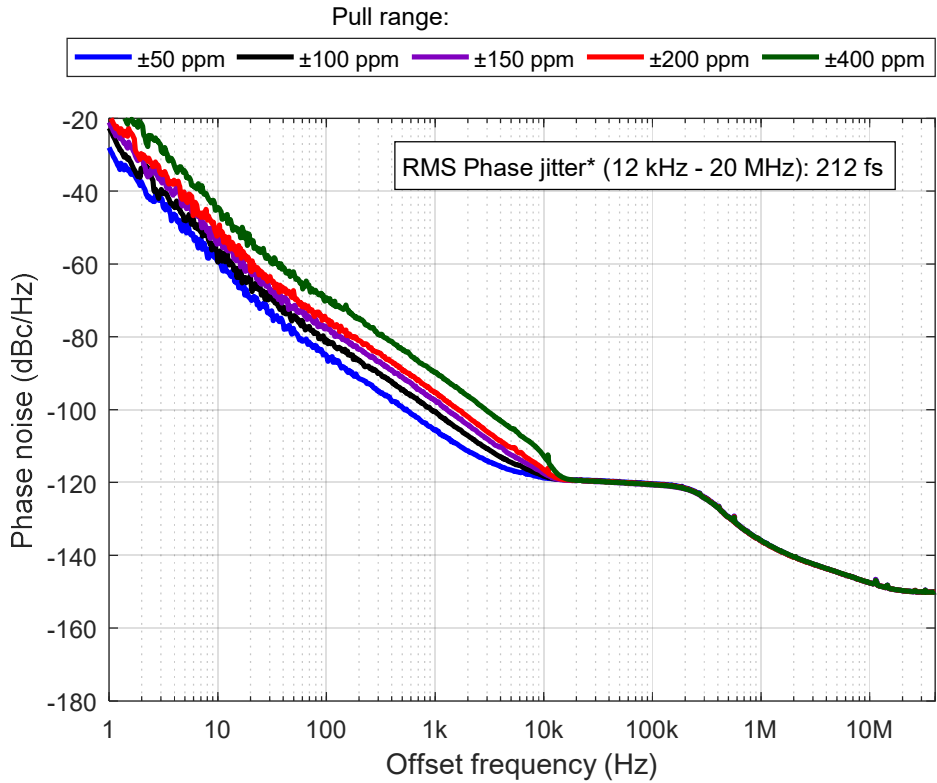

Figure 1: Phase noise, 3.3 V

**Integrated phase jitter value applies for ±50 ppm to ±400 ppm pull ranges*

Table 1: Phase noise

Phase noise dBc/Hz					
Frequency offset (Hz)	Pull range (ppm)				
	±50	±100	±150	±200	±400
1	-28.0	-22.6	-21.1	-19.0	-12.1
10	-59.3	-59.5	-54.4	-51.3	-44.4
100	-85.1	-81.0	-77.5	-75.1	-69.3
1 K	-105.6	-100.4	-97.4	-95.2	-89.6
10 K	-118.8	-118.3	-117.5	-116.5	-112.8
100 K	-120.4	-120.5	-120.7	-120.5	-120.6
1 M	-135.9	-136.0	-136.1	-136.0	-135.9
10 M	-147.6	-147.6	-147.6	-147.6	-147.6
40 M	-150.1	-150.1	-150.1	-150.1	-150.1

	Title:	Performance report for SiT3373, 625 MHz, LVPECL		
	Type:	Performance report	Rev:	1.2
	Orig:		Date:	September 07, 2018

Table 2: Integrated Phase jitter

Parameter	Units	Pull range (ppm)
		±50 to ±400
Integrated Phase jitter (1.875 MHz - 20 MHz)	fs, rms	74
Integrated Phase jitter (12 kHz - 20 MHz)	fs, rms	212

The information contained in this document is confidential and proprietary to SiTime Corporation. Unauthorized reproduction or distribution is prohibited.

	Title:	Performance report for SiT3373, 625 MHz, LVPECL		
	Type:	Performance report	Rev:	1.2
	Orig:		Date:	September 07, 2018



Figure 2: Output waveform, 2.5 V



Figure 3: Output waveform, 3.3 V

The information contained in this document is confidential and proprietary to SiTime Corporation. Unauthorized reproduction or distribution is prohibited.



Title:	Performance report for SiT3373, 625 MHz, LVPECL		
Type:	Performance report	Rev:	1.2
Orig:		Date:	September 07, 2018

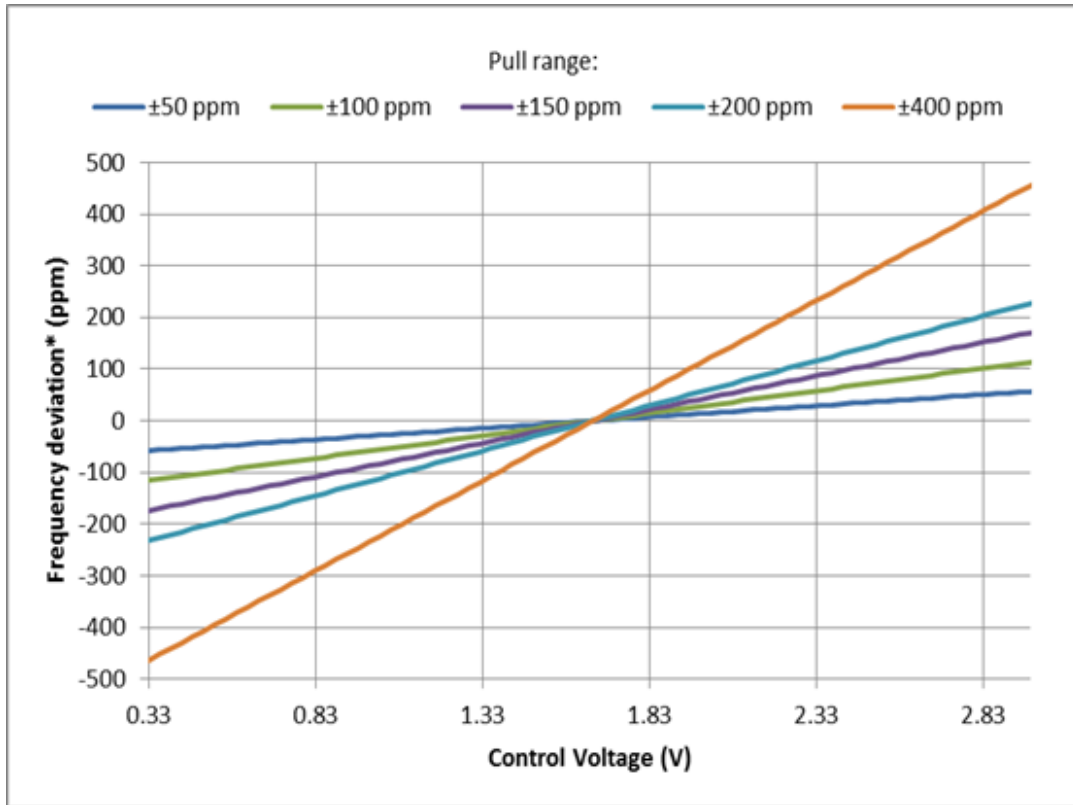

Figure 4: Frequency pull characteristic

SiTime	Title:	Performance report for SiT3373, 625 MHz, LVPECL		
	Type:	Performance report	Rev:	1.2
	Orig:		Date:	September 07, 2018

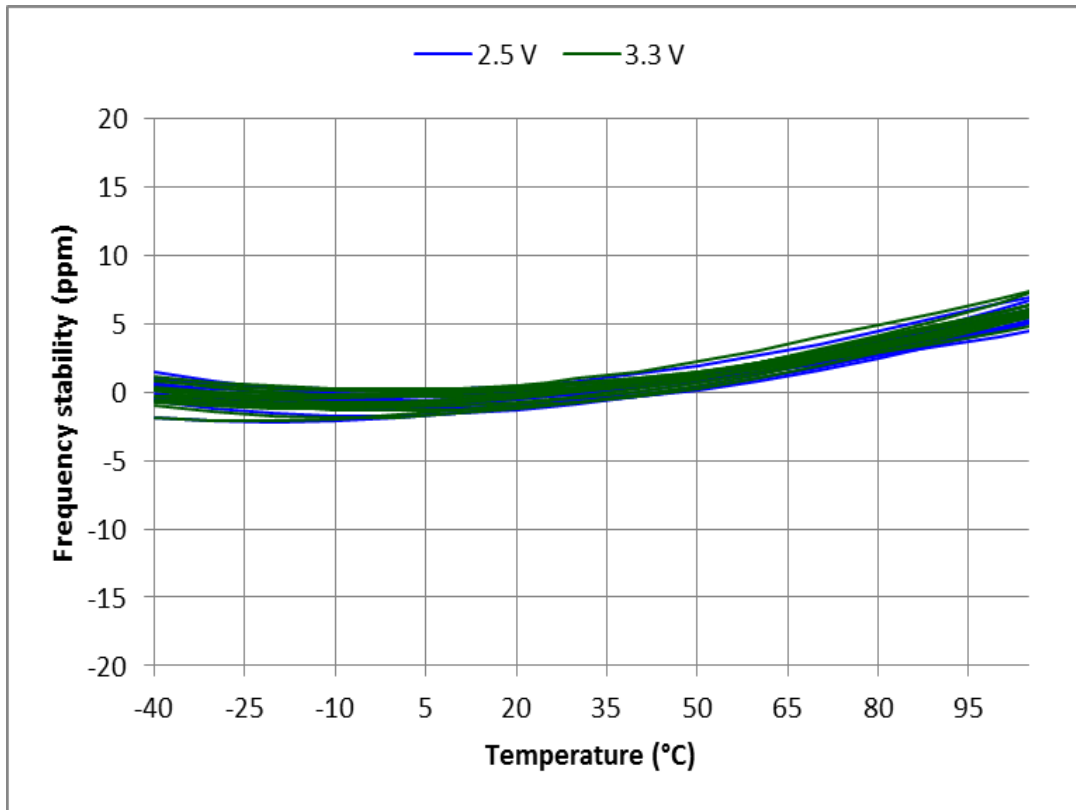

Figure 5: Frequency stability* over temperature, 2.5 V – 3.3 V, 30 devices

*SiT3373 frequency stability is independent of output frequency.

The information contained in this document is confidential and proprietary to SiTime Corporation. Unauthorized reproduction or distribution is prohibited.



	Title:	Performance report for SiT3373, 625 MHz, LVPECL		
	Type:	Performance report	Rev:	1.2
	Orig:		Date:	September 07, 2018

Table 3: Summary performance data

Parameter	Units	Voltage	
		2.5 V	3.3 V
Period jitter	ps, rms	0.97	1.16
Period jitter (sample size 10,000 cycles)	ps, pk-pk	8.27	8.30
Duty cycle	%	50.5	50.5
Rise time (20% - 80%)	ps	219	210
Fall time (80% - 20%)	ps	215	206
Differential voltage swing	V	1.49	1.48
Current consumption (no load, output enabled)	mA	77.9	78.3
Current consumption (no load, output disabled)	mA	54.0	54.1

	Title:	Performance report for SiT3373, 625 MHz, LVPECL		
	Type:	Performance report	Rev:	1.2
	Orig:		Date:	September 07, 2018

Test description

Conditions:

- Frequency: 625 MHz
- VDD: 2.5 V, 3.3 V
- Pull range: ± 50 ppm, ± 100 ppm, ± 150 ppm, ± 200 ppm, ± 400 ppm
- Temperature: 25 °C

Equipment:

Model	Measurement / Purpose
Keysight DSA90604A (6 GHz, 20 Gsps)	Period jitter, output amplitude, rise/fall time, duty cycle
Keysight 5052B Signal Source Analyzer	Phase noise, integrated phase jitter
Keysight 34980A	Power supply current
Keysight E3631A	Power supply
Keysight 53230A	Frequency

	Title:	Performance report for SiT3373, 625 MHz, LVPECL		
	Type:	Performance report	Rev:	1.2
	Orig:		Date:	September 07, 2018

Setup

Waveform

For waveform parameters measurement (rise/fall time, differential swing, duty cycle), both DUT outputs are terminated with $50\ \Omega$ to $VDD - 2\ V$. Output signals are measured using Keysight 1134B active probe with Keysight N5425B probe head. All measurements are applied to the differential waveform. Figure 6 shows test setup diagram for waveform parameters measurement.

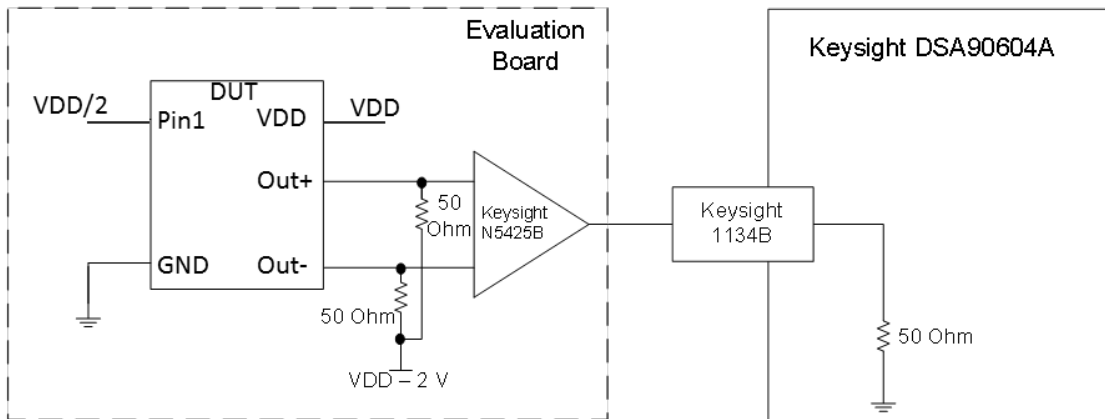

Figure 6. Test setup for measuring waveform parameters (rise/fall time, differential swing, duty cycle)

Period Jitter

For period jitter measurement output is terminated with $50\ \Omega$ to $VDD - 2\ V$ at the input of hi-speed comparator (ADCMP581). AC coupled comparator's output is connected to oscilloscope channel. Figure 7 shows test setup diagram for period jitter measurement.

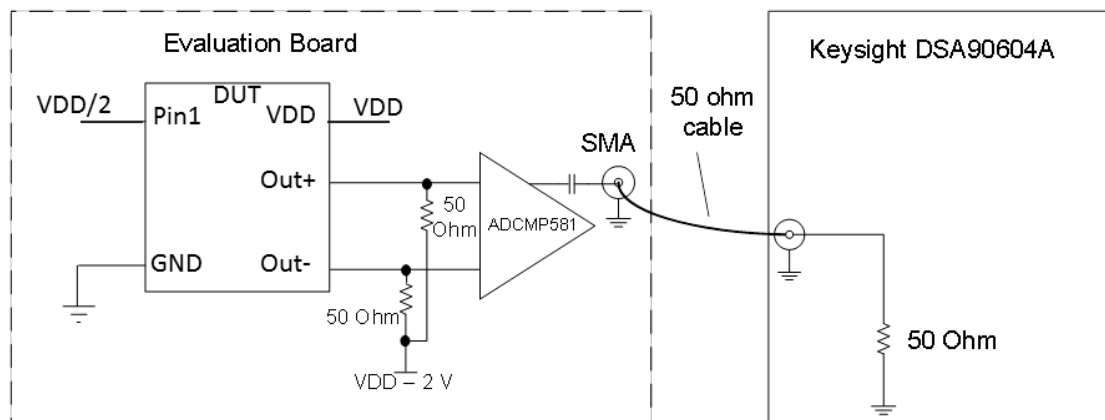



Figure 7. Test setup for measuring period jitter

	Title:	Performance report for SiT3373, 625 MHz, LVPECL		
	Type:	Performance report	Rev:	1.2
	Orig:		Date:	September 07, 2018

Phase noise

For phase noise measurements, differential signal is converted to single-ended using impedance matching transformer. Transformer's output is connected to measurement instrument. Figure 8 shows test setup diagram for phase noise measurement.

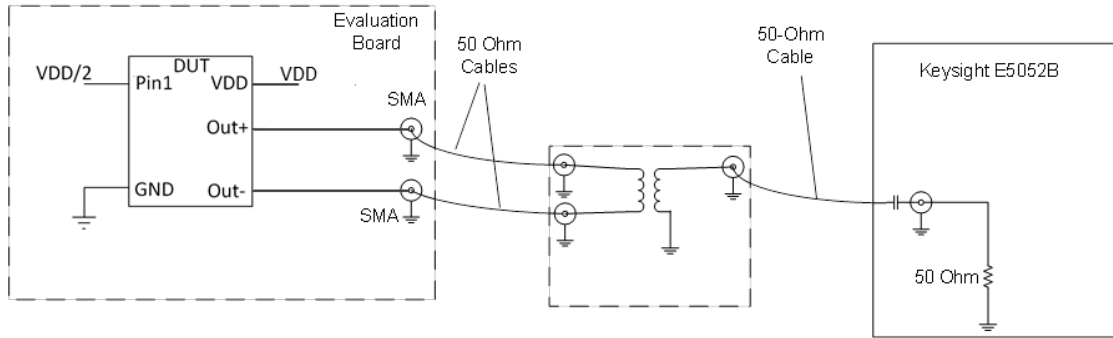

Figure 8. Test setup for measuring phase noise.

Current consumption

For Current consumption measurement device output is floating. For frequency measurement differential-to-single-ended converter is used.