	<b>Title:</b>	<b>Performance report for SiT5155, 10.949297 MHz, LVCMOS</b>		
	<b>Type:</b>	<b>Performance report</b>	<b>Rev:</b>	<b>1.2</b>
	<b>Orig:</b>		<b>Date:</b>	<b>July 17, 2018</b>

## Performance report for SiT5155 - 10.949297 MHz, LVCMOS

**Data:**

- Frequency stability over temperature
- Frequency slope
- Frequency hysteresis over temperature
- Allan Deviation
- MTIE
- TDEV
- Phase noise
- Output frequency power supply sensitivity
- Output frequency load sensitivity
- Output waveforms
- Pull range linearity
- Random Phase jitter, Period jitter, Duty cycle, Rise/Fall time, Amplitude, Current consumption



<b>Title:</b>	Performance report for SiT5155, 10.949297 MHz, LVCMOS		
<b>Type:</b>	Performance report	<b>Rev:</b>	1.2
<b>Orig:</b>		<b>Date:</b>	July 17, 2018

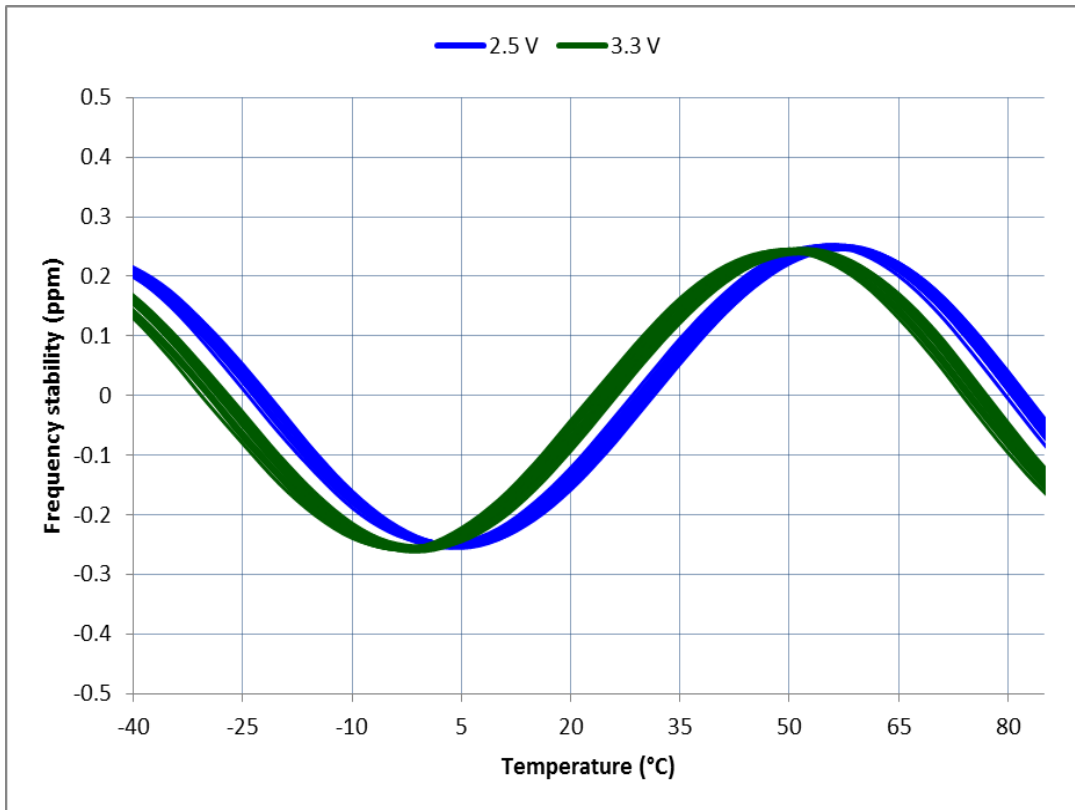

Figure 1: Frequency stability\* over temperature, 2.5 V – 3.3 V, 30 devices

\*SiT5155 frequency stability is independent of output frequency.



<b>Title:</b>	Performance report for SiT5155, 10.949297 MHz, LVCMOS		
<b>Type:</b>	Performance report	<b>Rev:</b>	1.2
<b>Orig:</b>		<b>Date:</b>	July 17, 2018

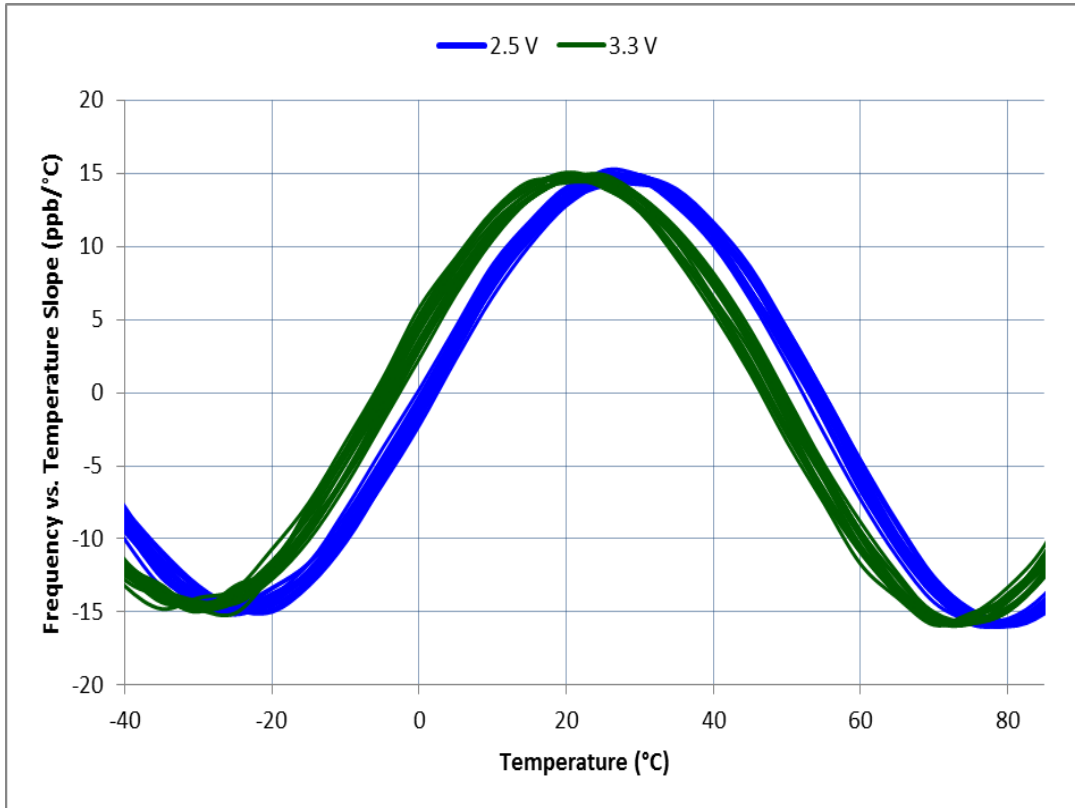

Figure 2: Frequency versus temperature slope, 30 devices

<b>Title:</b>	Performance report for SiT5155, 10.949297 MHz, LVCMOS		
<b>Type:</b>	Performance report	<b>Rev:</b>	1.2
<b>Orig:</b>		<b>Date:</b>	July 17, 2018

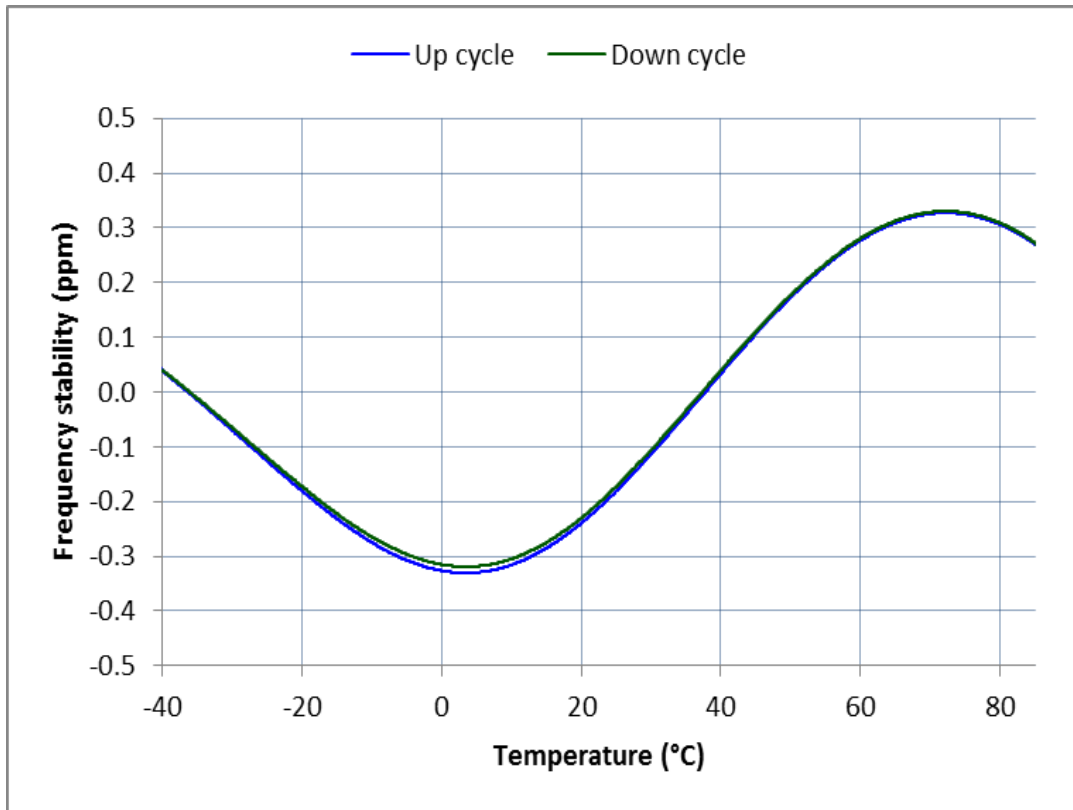

Figure 3: Frequency hysteresis over temperature, temperature ramp rate 0.5°C/min

<b>SiTime</b>	<b>Title:</b>	Performance report for SiT5155, 10.949297 MHz, LVCMOS		
	<b>Type:</b>	Performance report	<b>Rev:</b>	1.2
	<b>Orig:</b>		<b>Date:</b>	July 17, 2018

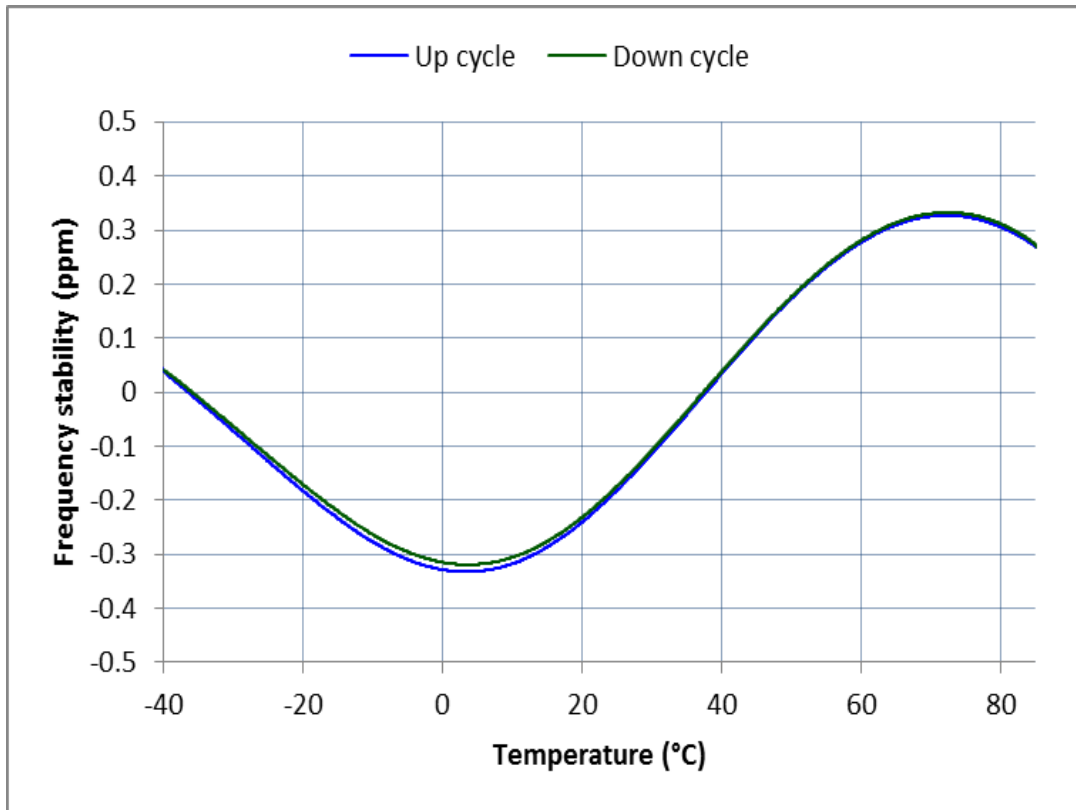

Figure 4: Frequency hysteresis over temperature, temperature ramp rate 1°C/min

The information contained in this document is confidential and proprietary to SiTime Corporation. Unauthorized reproduction or distribution is prohibited.

<b>SiTime</b>	<b>Title:</b>	Performance report for SiT5155, 10.949297 MHz, LVCMOS		
	<b>Type:</b>	Performance report	<b>Rev:</b>	1.2
	<b>Orig:</b>		<b>Date:</b>	July 17, 2018

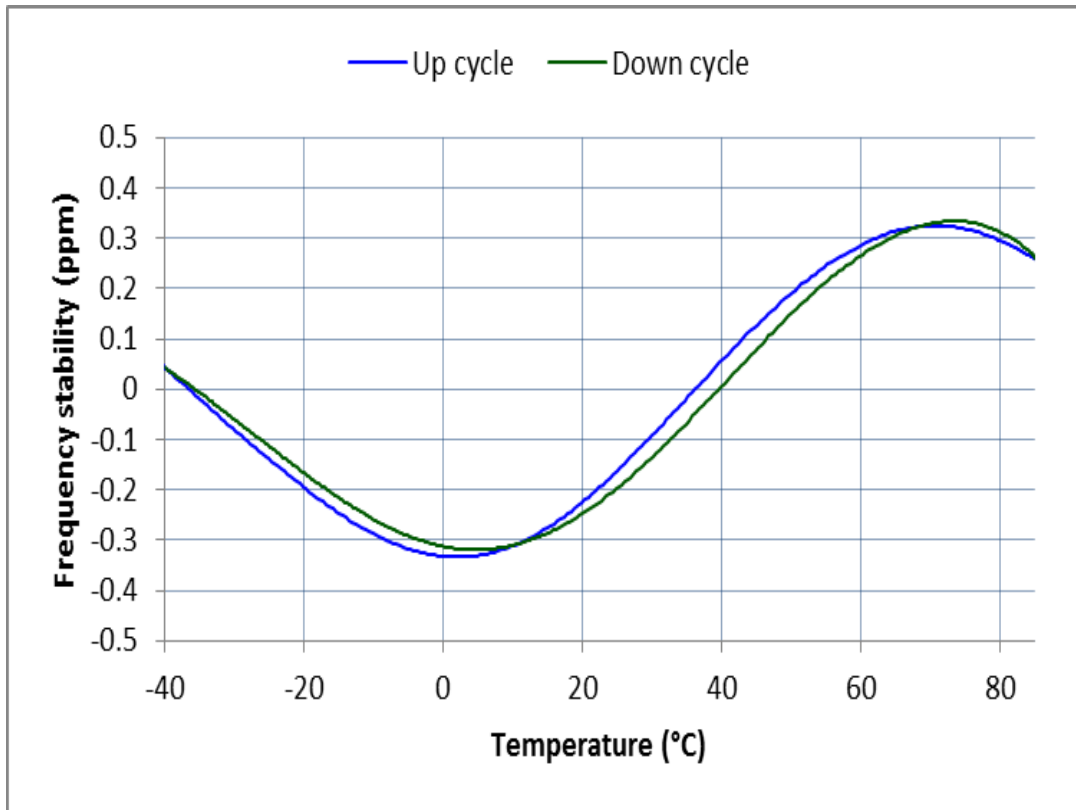

Figure 5: Frequency hysteresis over temperature, temperature ramp rate 8°C/min

**The information contained in this document is confidential and proprietary to SiTime Corporation. Unauthorized reproduction or distribution is prohibited.**

<b>SiTime</b>	<b>Title:</b>	Performance report for SiT5155, 10.949297 MHz, LVC MOS		
	<b>Type:</b>	Performance report	<b>Rev:</b>	1.2
	<b>Orig:</b>		<b>Date:</b>	July 17, 2018

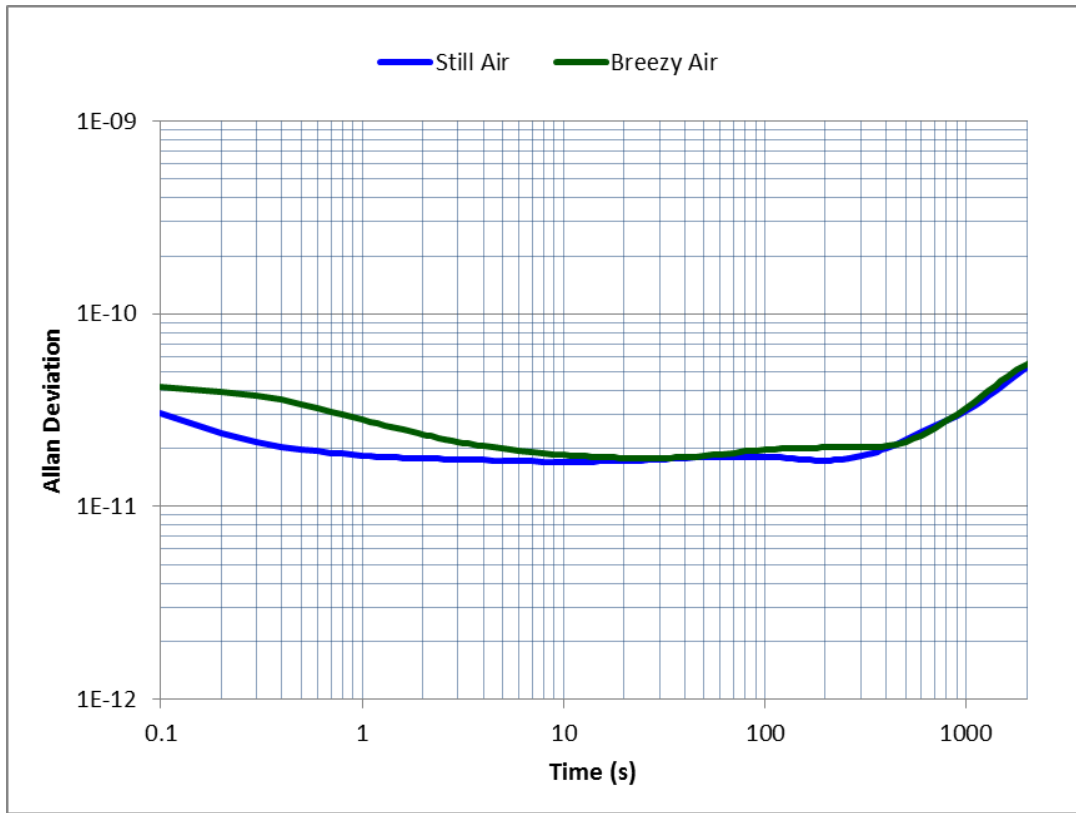

Figure 6: Allan deviation

Table 1: Allan deviation

Time (s)	0.1	1	10	100	1000
Still Air	3.04E-11	1.84E-11	1.71E-11	1.81E-11	3.16E-11
Breezy Air	4.17E-11	2.82E-11	1.85E-11	1.98E-11	3.26E-11



<b>Title:</b>	Performance report for SiT5155, 10.949297 MHz, LVCMOS		
<b>Type:</b>	Performance report	<b>Rev:</b>	1.2
<b>Orig:</b>		<b>Date:</b>	July 17, 2018

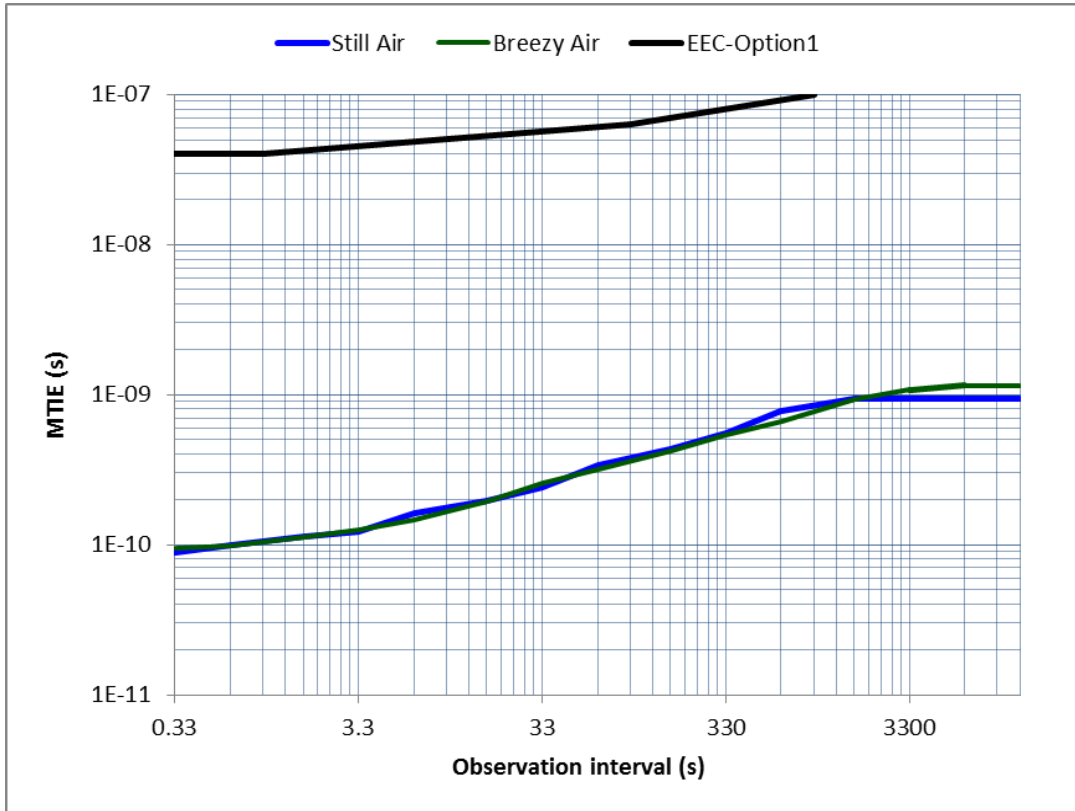

The information contained in this document is confidential and proprietary to SiTime Corporation. Unauthorized reproduction or distribution is prohibited.





<b>Title:</b>	Performance report for SiT5155, 10.949297 MHz, LVC MOS		
<b>Type:</b>	Performance report	<b>Rev:</b>	1.2
<b>Orig:</b>		<b>Date:</b>	July 17, 2018

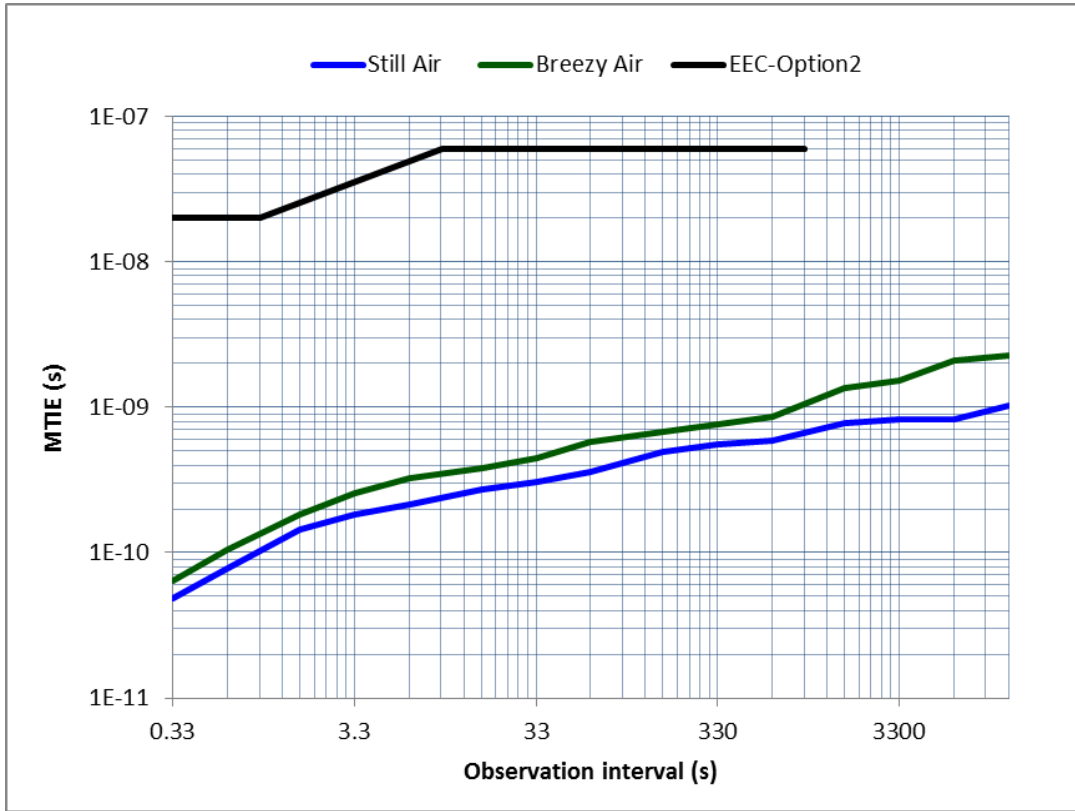

Figure 8: MTIE (PLL bandwidth = 0.1 Hz)



<b>Title:</b>	Performance report for SiT5155, 10.949297 MHz, LVCMOS		
<b>Type:</b>	Performance report	<b>Rev:</b>	1.2
<b>Orig:</b>		<b>Date:</b>	July 17, 2018

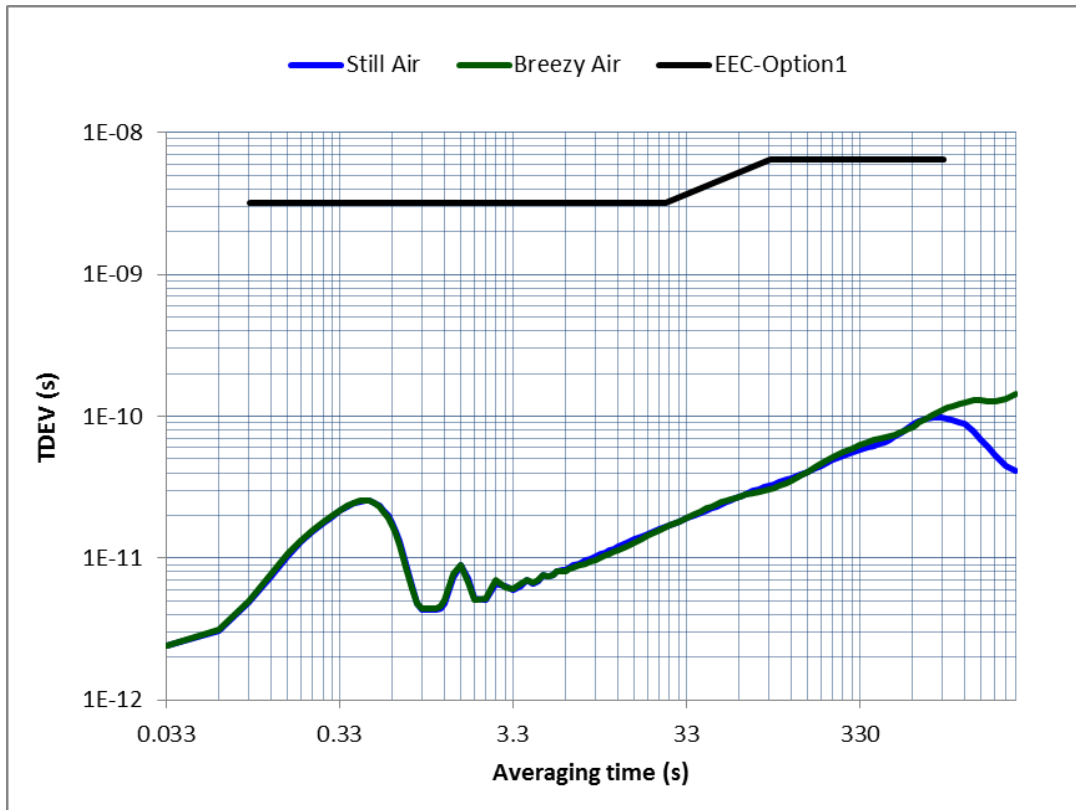

Figure 9: TDEV (PLL bandwidth = 3 Hz)



<b>Title:</b>	Performance report for SiT5155, 10.949297 MHz, LVCMOS		
<b>Type:</b>	Performance report	<b>Rev:</b>	1.2
<b>Orig:</b>		<b>Date:</b>	July 17, 2018

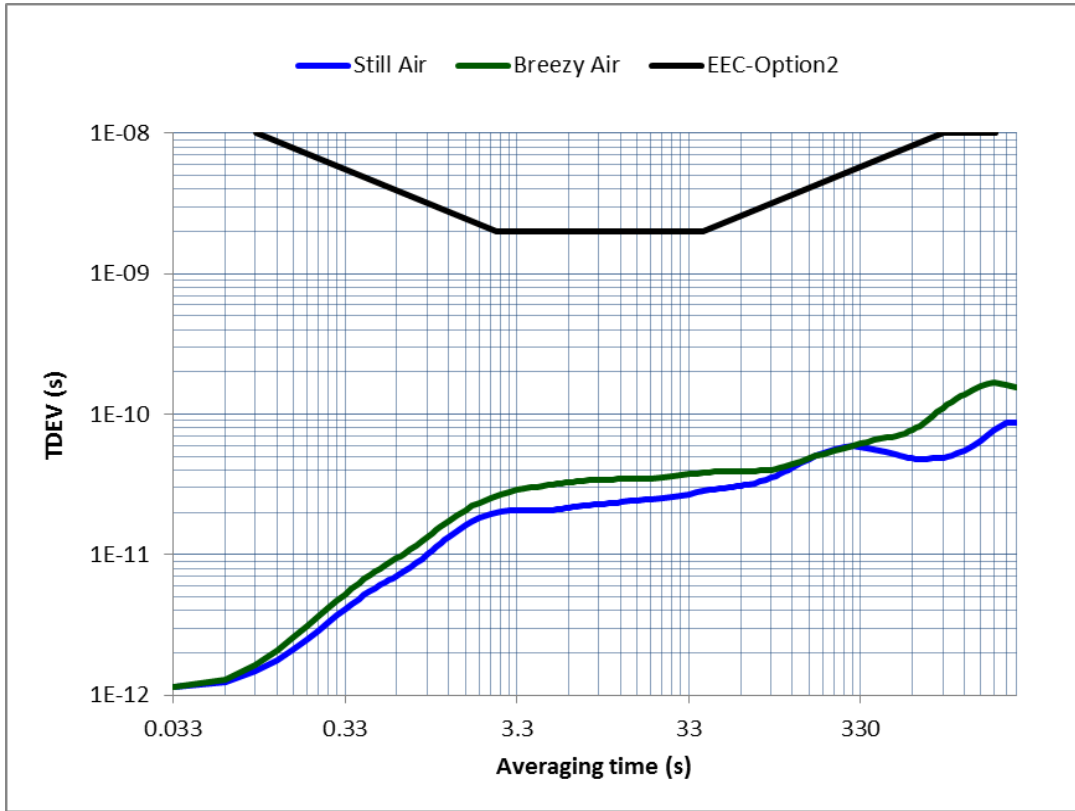

Figure 10: TDEV (PLL bandwidth = 0.1 Hz)

<b>SiTime</b>	<b>Title:</b>	<b>Performance report for SiT5155, 10.949297 MHz, LVCMOS</b>		
	<b>Type:</b>	<b>Performance report</b>	<b>Rev:</b>	<b>1.2</b>
	<b>Orig:</b>		<b>Date:</b>	<b>July 17, 2018</b>

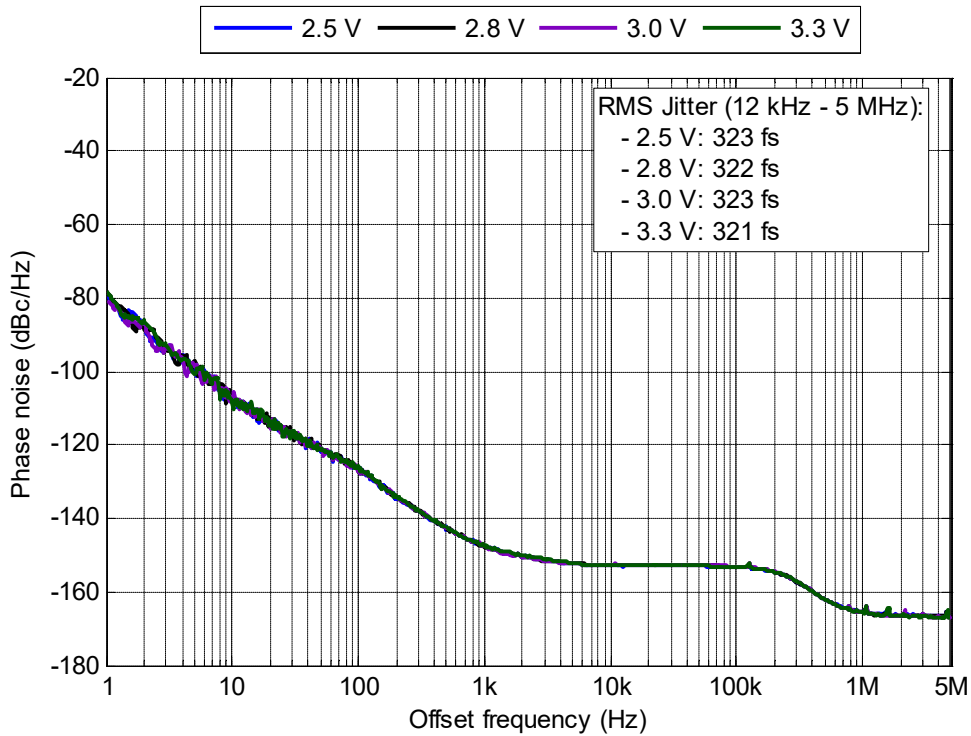



Figure 11: Phase noise TCXO/DCTCXO, 2.5 V - 3.3 V

Table 2: Phase noise TCXO/DCTCXO

Voltage	Phase noise (dBc/Hz)							
	1 Hz	10 Hz	100 Hz	1 KHz	10 KHz	100 KHz	1 MHz	5 MHz
2.5 V	-79.0	-108.0	-126.1	-147.6	-152.9	-153.3	-165.5	-166.6
2.8 V	-78.3	-108.2	-127.1	-147.5	-152.9	-153.2	-165.6	-166.7
3.0 V	-80.1	-107.9	-126.8	-147.3	-152.8	-153.1	-165.6	-166.9
3.3 V	-78.1	-108.4	-125.6	-147.8	-152.9	-153.2	-165.7	-167.0

	<b>Title:</b>	Performance report for SiT5155, 10.949297 MHz, LVCMOS		
	<b>Type:</b>	Performance report	<b>Rev:</b>	1.2
	<b>Orig:</b>		<b>Date:</b>	July 17, 2018

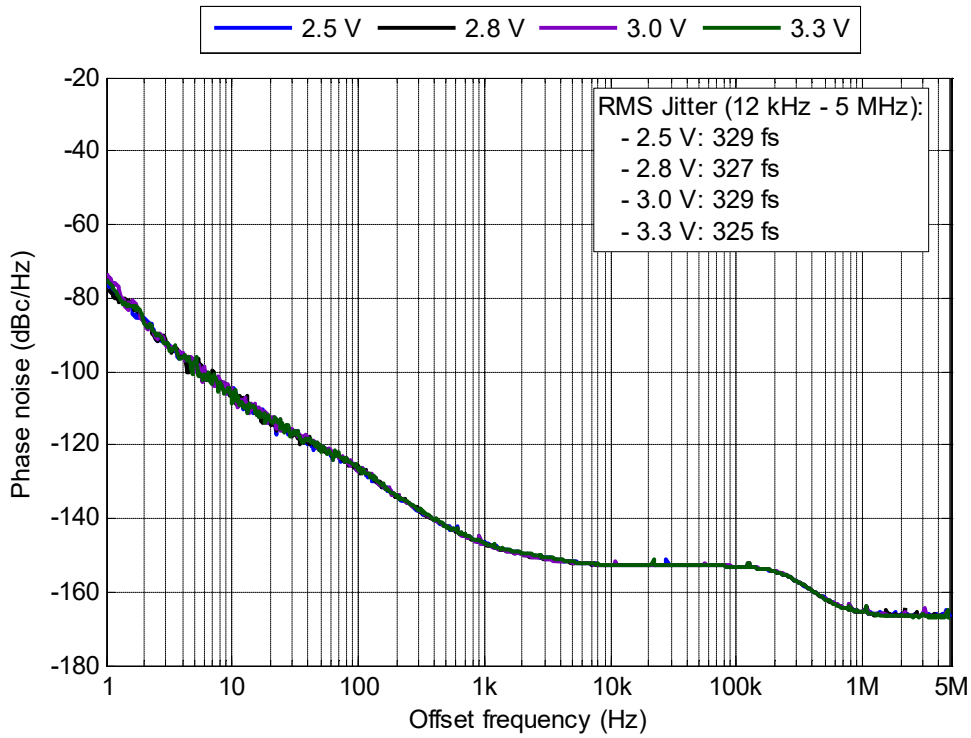

Figure 12: Phase noise VCTCXO, 2.5 V - 3.3 V

Table 3: Phase noise VCTCXO

Voltage	Phase noise (dBc/Hz)							
	1 Hz	10 Hz	100 Hz	1 KHz	10 KHz	100 KHz	1 MHz	5 MHz
2.5 V	-76.1	-105.3	-126.8	-146.6	-152.6	-153.1	-165.4	-166.6
2.8 V	-76.9	-106.5	-126.2	-147.0	-152.7	-153.1	-165.5	-166.7
3.0 V	-73.5	-106.1	-126.0	-147.0	-152.6	-153.1	-165.5	-166.7
3.3 V	-74.9	-108.7	-126.3	-146.8	-152.7	-153.1	-165.6	-167.0

<b>SiTime</b>	<b>Title:</b>	Performance report for SiT5155, 10.949297 MHz, LVCMOS		
	<b>Type:</b>	Performance report	<b>Rev:</b>	1.2
	<b>Orig:</b>		<b>Date:</b>	July 17, 2018

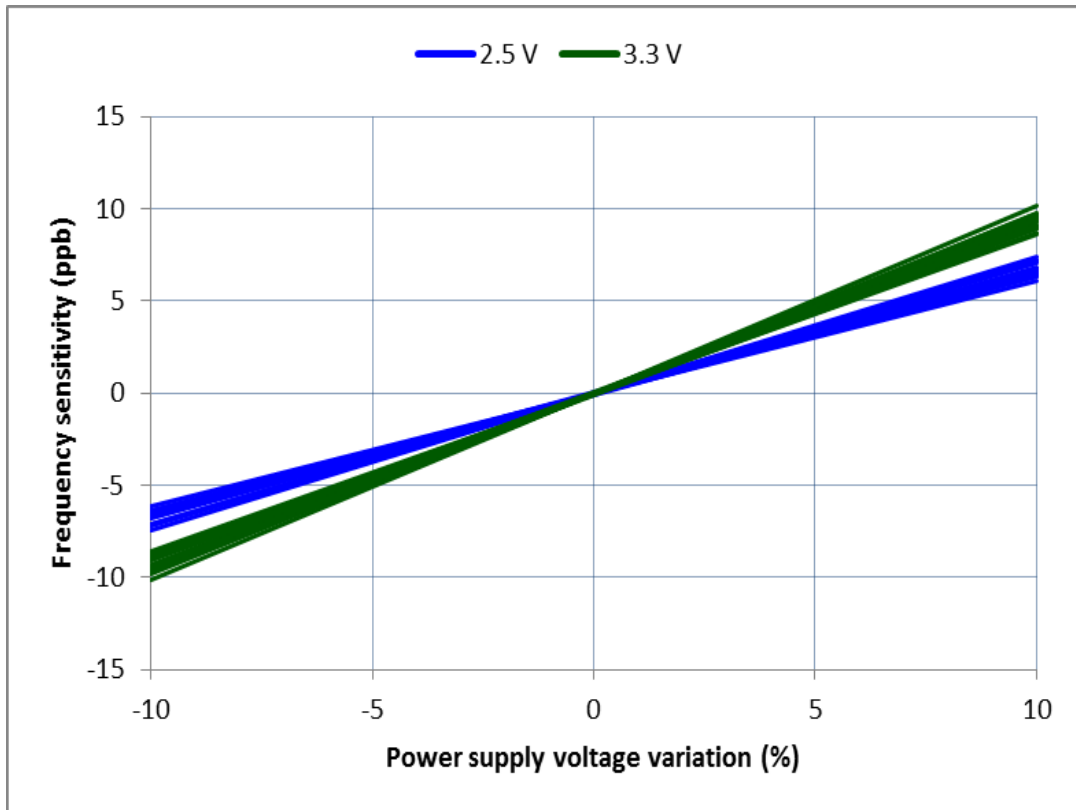

Figure 13: Output frequency power supply sensitivity, 30 devices

**The information contained in this document is confidential and proprietary to SiTime Corporation. Unauthorized reproduction or distribution is prohibited.**



<b>Title:</b>	Performance report for SiT5155, 10.949297 MHz, LVCMOS		
<b>Type:</b>	Performance report	<b>Rev:</b>	1.2
<b>Orig:</b>		<b>Date:</b>	July 17, 2018

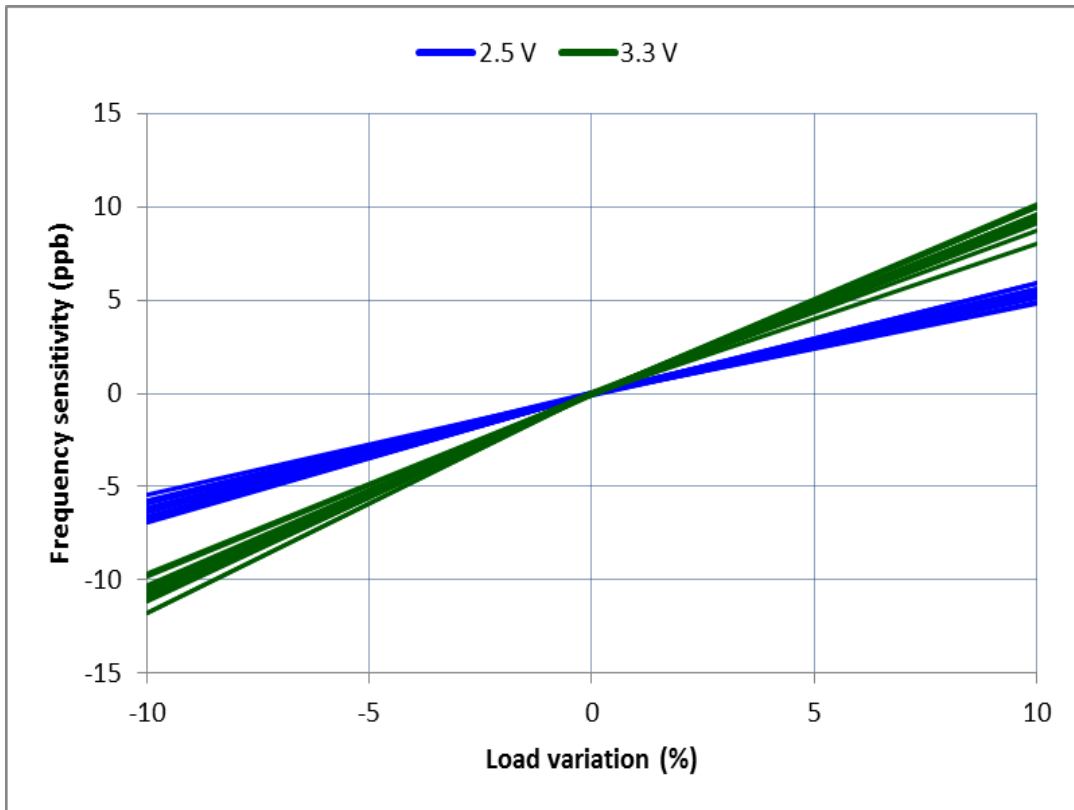

Figure 14: Output frequency load sensitivity, 30 devices

	<b>Title:</b>	Performance report for SiT5155, 10.949297 MHz, LVCMOS		
	<b>Type:</b>	Performance report	<b>Rev:</b>	1.2
	<b>Orig:</b>		<b>Date:</b>	July 17, 2018



Figure 15: Output waveform, 2.5 V



	<b>Title:</b>	Performance report for SiT5155, 10.949297 MHz, LVCMOS		
	<b>Type:</b>	Performance report	<b>Rev:</b>	1.2
	<b>Orig:</b>		<b>Date:</b>	July 17, 2018



Figure 16: Output waveform, 2.8 V

	<b>Title:</b>	Performance report for SiT5155, 10.949297 MHz, LVCMOS		
	<b>Type:</b>	Performance report	<b>Rev:</b>	1.2
	<b>Orig:</b>		<b>Date:</b>	July 17, 2018



Figure 17: Output waveform, 3.0 V

The information contained in this document is confidential and proprietary to SiTime Corporation. Unauthorized reproduction or distribution is prohibited.

	<b>Title:</b>	Performance report for SiT5155, 10.949297 MHz, LVCMOS		
	<b>Type:</b>	Performance report	<b>Rev:</b>	1.2
	<b>Orig:</b>		<b>Date:</b>	July 17, 2018



Figure 18: Output waveform, 3.3 V

<b>SiTime</b>	<b>Title:</b>	Performance report for SiT5155, 10.949297 MHz, LVCMOS		
	<b>Type:</b>	Performance report	<b>Rev:</b>	1.2
	<b>Orig:</b>		<b>Date:</b>	July 17, 2018

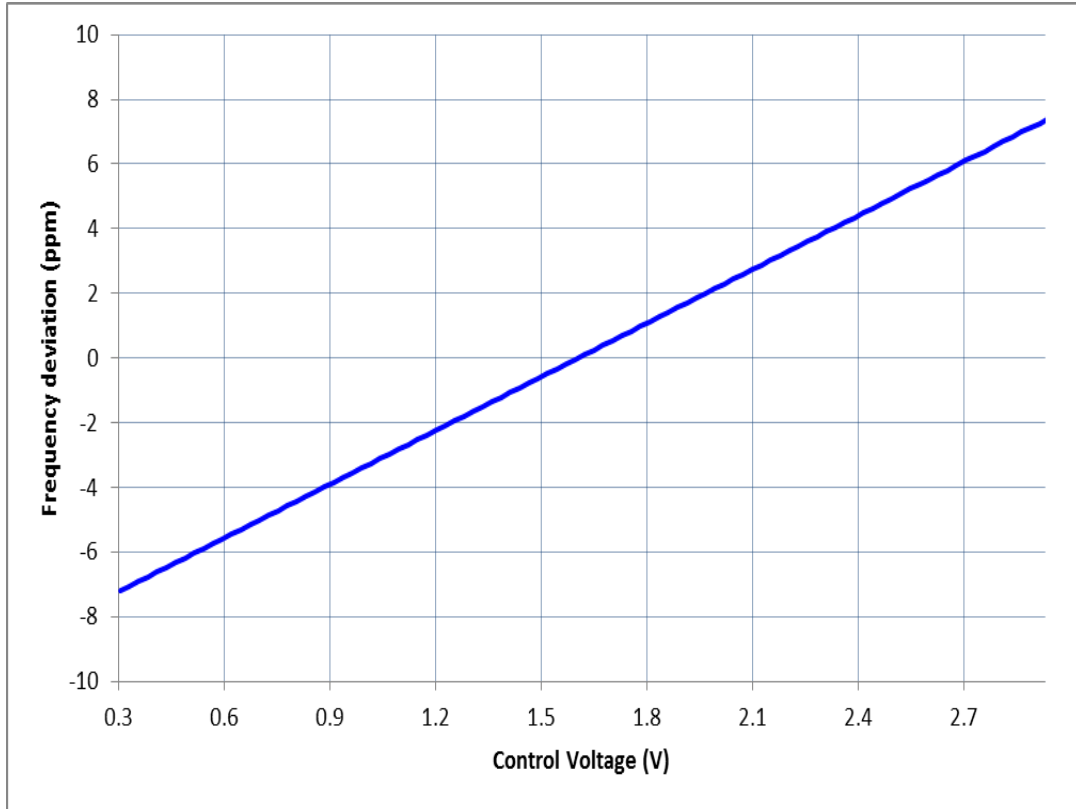

Figure 19: Pull range linearity VCTCXO.

\*Referred to the output frequency for control voltage equal to VDD/2

**The information contained in this document is confidential and proprietary to SiTime Corporation. Unauthorized reproduction or distribution is prohibited.**

<b>SiTime</b>	<b>Title:</b>	Performance report for SiT5155, 10.949297 MHz, LVCMOS		
	<b>Type:</b>	Performance report	<b>Rev:</b>	1.2
	<b>Orig:</b>		<b>Date:</b>	July 17, 2018

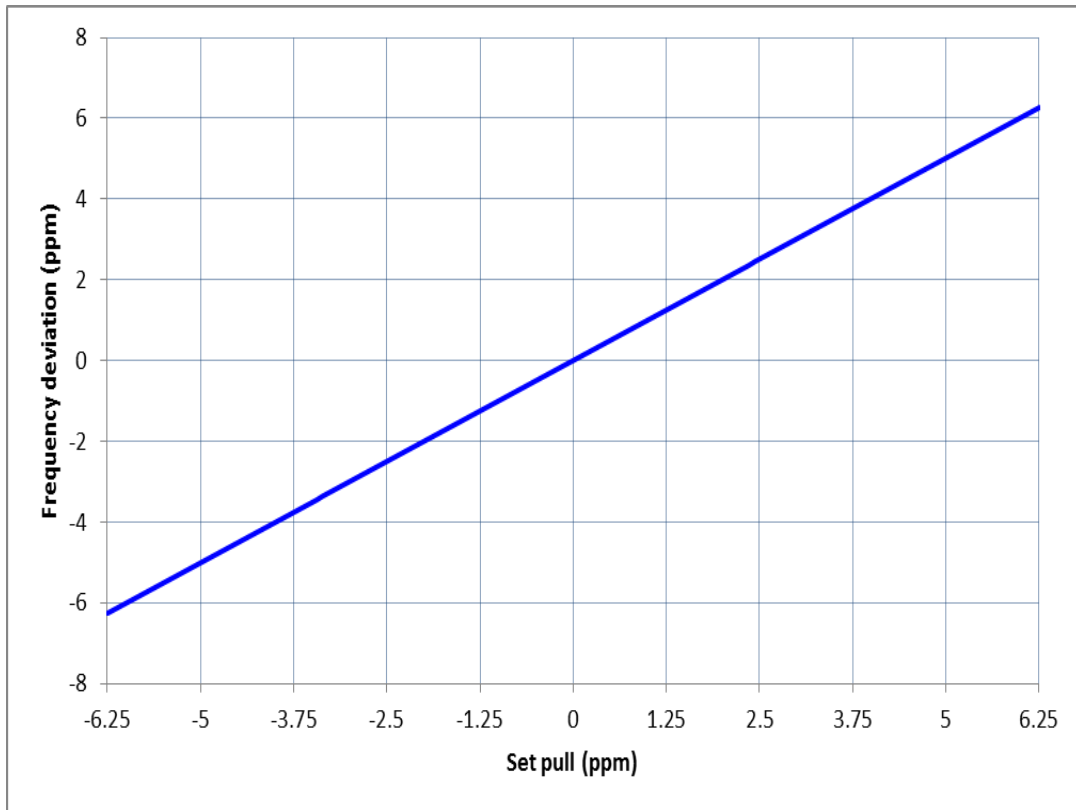

Figure 20: Pull range linearity DCTCXO.

\*Referred to the output frequency for frequency control value equal to 0

**The information contained in this document is confidential and proprietary to SiTime Corporation. Unauthorized reproduction or distribution is prohibited.**

	<b>Title:</b>	<b>Performance report for SiT5155, 10.949297 MHz, LVCMOS</b>		
	<b>Type:</b>	<b>Performance report</b>	<b>Rev:</b>	<b>1.2</b>
	<b>Orig:</b>		<b>Date:</b>	<b>July 17, 2018</b>

Table 4: Summary performance data

Parameter	Units	Voltage			
		2.5 V	2.8 V	3.0 V	3.3 V
TCXO/DCTCXO Integrated Phase jitter (12 kHz - 5 MHz)	fs, rms	323	322	323	321
VCTCXO Integrated Phase jitter (12 kHz - 5 MHz)	fs, rms	329	327	329	325
Period jitter	ps, rms	1.08	-	-	1.05
Period jitter (10,000 cycles)	ps, pk-pk	8.28	-	-	8.25
Duty cycle	%	50.3	50.3	50.2	50.2
Rise time (10% - 90%)	ps	1.08	1.04	1.10	0.99
Fall time (90% - 10%)	ps	1.04	1.03	1.09	1.02
Amplitude	V	2.52	2.81	3.03	3.35
Current consumption TCXO (no load)	mA	43.7	43.7	43.7	43.9
Current consumption VCTCXO (no load)	mA	47.1	47.2	47.3	47.4
Current consumption DCTCXO (no load)	mA	44.1	44.2	44.3	44.4

**Conditions:**

- Frequency: 10.949297 MHz
- VDD: 2.5 V, 2.8 V, 3.0 V, 3.3 V
- Pull range:  $\pm 6.25$  ppm
- Temperature: 25 °C

**Equipment:**

Model	Measurement / Purpose
Keysight DSA90604A (6 GHz, 20 Gsps)	Period jitter, output amplitude, rise/fall time, duty cycle
Keysight 5052B Signal Source Analyzer	Phase noise, integrated phase jitter
Keysight 34980A	Power supply current
Keysight E3631A	Power supply
Keysight 53230A	Frequency

**Test setup:**

For waveform parameters measurement (rise/fall time, amplitude, duty cycle), DUT output is loaded with 15 pF. Output signal is measured using Keysight 1134B active probe with Keysight N5425B probe head. Figure 21 shows test setup diagram for waveform parameters measurement.

	<b>Title:</b>	Performance report for SiT5155, 10.949297 MHz, LVCMOS		
	<b>Type:</b>	Performance report	<b>Rev:</b>	1.2
	<b>Orig:</b>		<b>Date:</b>	July 17, 2018

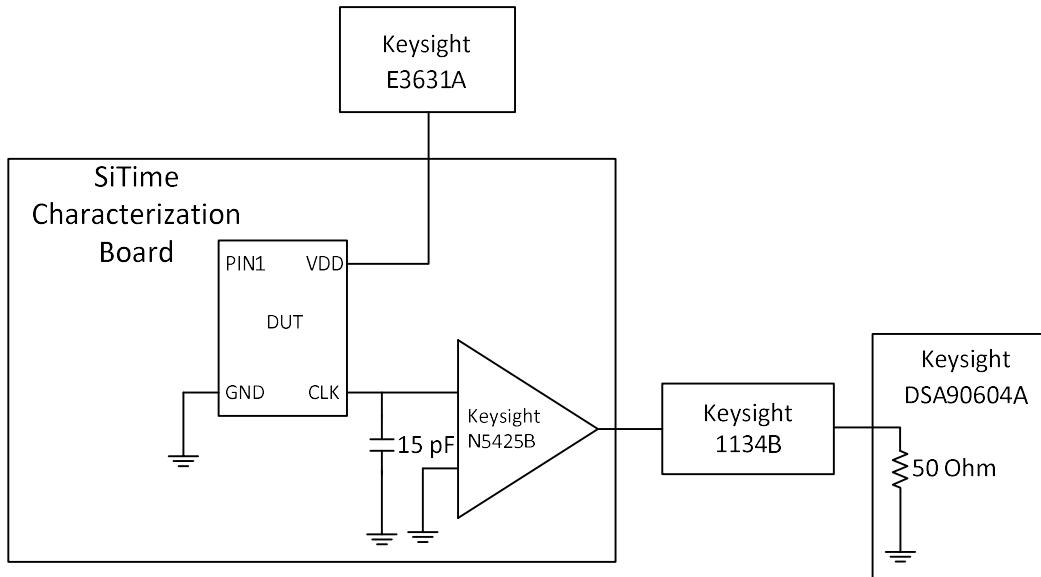

Figure 21: Test setup for measuring waveform parameters (rise/fall time, amplitude, duty cycle)

For period jitter measurement output is loaded with 15 pF. Jitter is measured from the output of hi-speed comparator (ADCMP581). AC coupled comparator's output is connected to oscilloscope channel. Figure 22 shows test setup diagram for period jitter measurement.

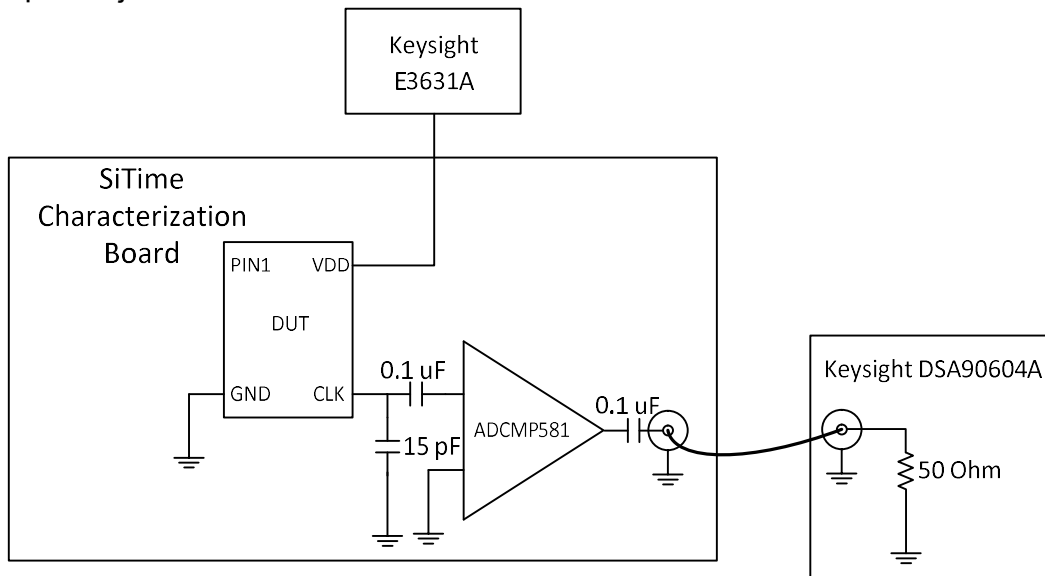



Figure 22: Test setup for measuring period jitter

	<b>Title:</b>	Performance report for SiT5155, 10.949297 MHz, LVCMOS		
	<b>Type:</b>	Performance report	<b>Rev:</b>	1.2
	<b>Orig:</b>		<b>Date:</b>	July 17, 2018

For phase noise measurements output is connected to 50 Ω measurement instrument input through AC coupling capacitor. Figure 23 shows test setup diagram for phase noise measurement.

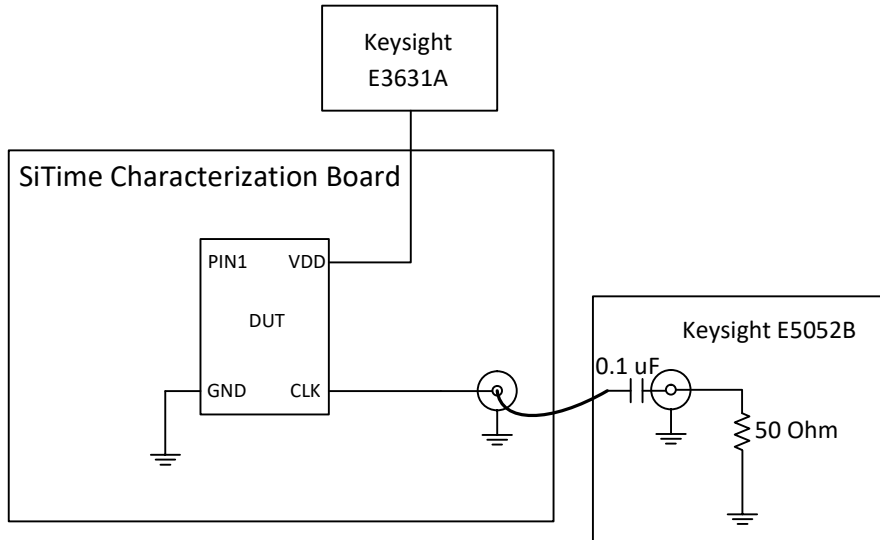

Figure 23: Test setup for measuring phase noise

For frequency measurement (stability over temperature, frequency hysteresis, stability over voltage, stability over load, ADEV) buffered device output is connected to 50 Ω measurement instrument input (see figure 24).

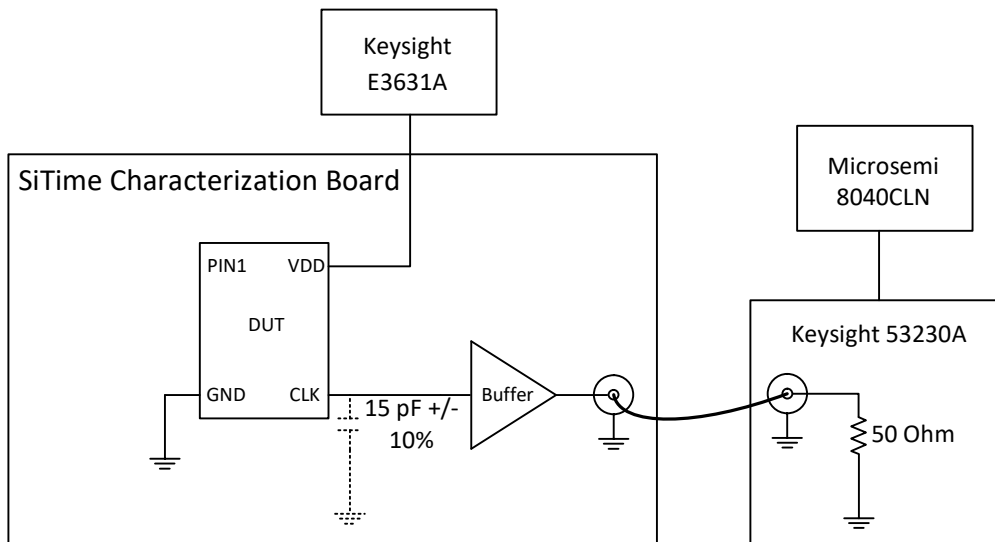

Figure 24: Test setup for measuring frequency



<b>SiTime</b>	<b>Title:</b>	<b>Performance report for SiT5155, 10.949297 MHz, LVCMOS</b>		
	<b>Type:</b>	<b>Performance report</b>	<b>Rev:</b>	<b>1.2</b>
	<b>Orig:</b>		<b>Date:</b>	<b>July 17, 2018</b>

For wander (MTIE, TDEV) measurement AD9548 DPLL is used. DPLL is referenced from rubidium frequency reference. SiTime Super-TCXO is used as system clock for DPLL programmed to different bandwidths. Frequency is measured continuously (gap free mode) with 33 ms gate time. Figure 25 shows setup diagram for wander measurements.

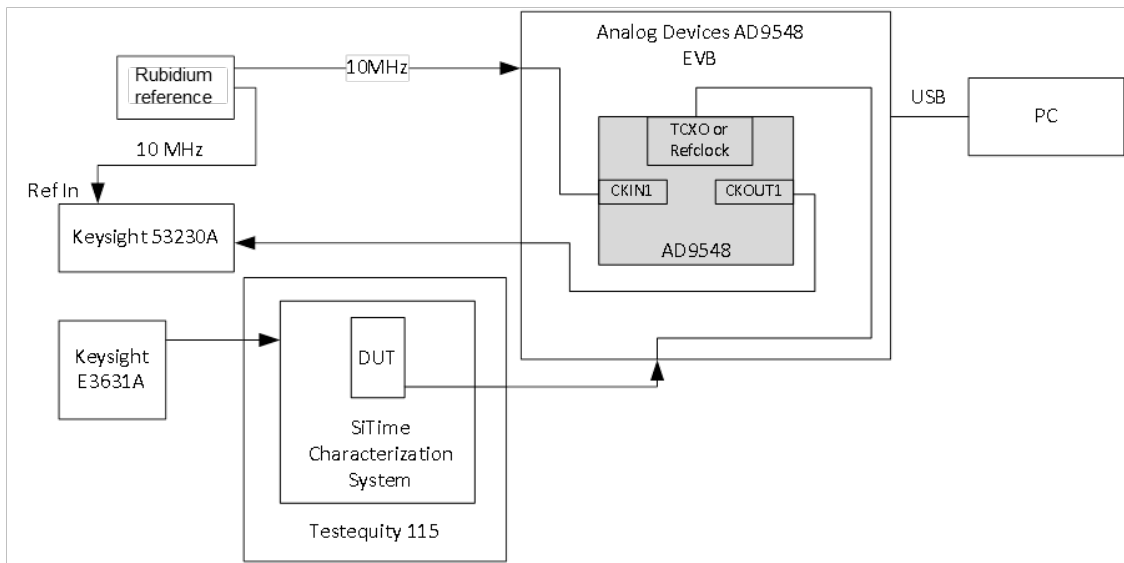

Figure 25: Test setup for measuring wander